

Lift control panel



**tetra**

# INSTALLATION MANUAL

for traction lifts

## Besoin d'aide technique ?



Chat en ligne : [www.sprinte.eu](http://www.sprinte.eu)



Whatsapp SAV : +33 7 57 90 13 63



Telephone : +33 4 75 63 77 77



## Table of contents

Consignes de sécurité / Safety rules .....	4
Mode provisoire / Temporary operation .....	5
Etape 1 / Step 1 .....	5
Boitier provisoire / Temporary box .....	6
Données moteur / Motor's datas .....	8
Données codeur / Encoder's datas .....	11
Déplacement / Movement .....	13
Positionnement en gaine / Shaft positioning system .....	14
Composition .....	14
Montage de la bande / Mounting of the tape .....	15
Montage du lecteur / Mounting of the reader .....	17
Phase de positionnement / Shaft's learning phase .....	18
Précision d'arrêt / Regulation stopping accuracy .....	19
Vitesses de déplacement / Moving speeds .....	19
Correction de la régulation / Regulation correction .....	20
Profil du déplacement / Movement profile .....	21
Réglages pour moteur à fort glissement / Settings for high slip motor .....	25
Réglage des niveaux / Floors adjustment .....	27
Isonivelage / Releveling .....	29
Installation .....	29
Synoptiques électriques / Electrical synopsis .....	30
Topologie des Bus CAN / CAN buses architecture .....	30
Diagnostic / Diagnosis .....	32
Alimentation / Power supply .....	33
Armoire / Controller .....	33
Traction / Hoist .....	34
Traction hydraulique / Hydraulic hoist .....	34
Traction électrique / Electric hoist .....	35
Position .....	36
Isonivelage / Releveling .....	37
Taquets de chargement / Loading pawls devices .....	37
Autres défauts / Other faults .....	37
Portes / Doors .....	38
Chaîne de sécurité / Safety chain .....	38
VF .....	39
Annexes: Assistance aux tests / Annex : Tests assistance .....	39
Test parachute / Safety gear test .....	39
Test autocontrôle des freins / Brakes self-monitoring test .....	40
Test autocontrôle des freins / Brakes self-monitoring test .....	41
Test survitesse montée / Upward overspeed protection mean test .....	42
Test de l'antipatinage / Anti-skidding test .....	43
Test des FCE / End limit switches test .....	44
Test de la dérive / Test of the natural movement of the car .....	45
Test de l'effort de freinage / Braking force test .....	46
Test de l'efficacité des freins / Brakes efficiency test .....	47
Test de l'isonivelage / Re-leveling test .....	48
Test de l'UCMP / UCMP Test .....	49
Résistance d'isolement / Measurement of the insulation resistance .....	50
Déclenchement limiteur / Tripping overspeed governor .....	52
Réarmement limiteur / Overspeed governor reset .....	53

## Safety rules

Some informations need particular attention, it will be marked as follow all through this document

### DANGER

Risk of death or serious accident if procedures are not followed.

### ATTENTION

Risk of accident or materials damage if procedures are not followed

### IMPORTANT

Mandatory instruction to follow to ensure the proper operation and safety of the lift.

### NOTE

Recommendation to make operations efficient and avoid minor problems

These informations could be accompanied with the following symbols (EN ISO 7010:2012 compliant) :



. General danger



. Danger, electrical voltage



. Parts susceptible to damage by ESD



. Danger, hot surface



. Danger, rotating parts



. Danger, risk of falling



. Danger, risk of crushing



Obligation to shutdown electrical power supply before any operation



Obligation to wear a protection helmet



Obligation to wear protection gloves



Obligation to wear protection visor

Edition version: 2026-03-06.

## Temporary operation

**DANGER**



Temporary operation shall be used only during installation of the lift by authorized and skilled technicians.

### Step 1 : electrical wiring

**DANGER**



All the wiring process shall be done with power supply off

#### • CABLES SHIELDING

In order to avoid operational problems due to electromagnetic interferences, it is essential to connect the power cable shielding at each end, to the boxes' plates or motor housing

At the end of the cable, remove a part of the sheath a little bit larger than the clamp:

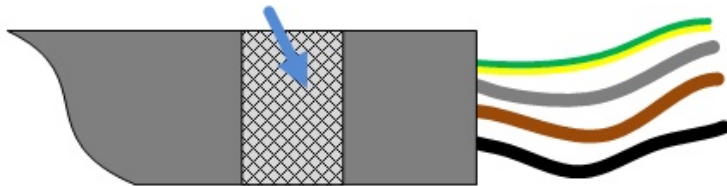

- Flanges to bend (in most of the boxes of the controller)

Bend the flange around the shield, presse the clamp to the plate, and screw it in the hole dedicated:

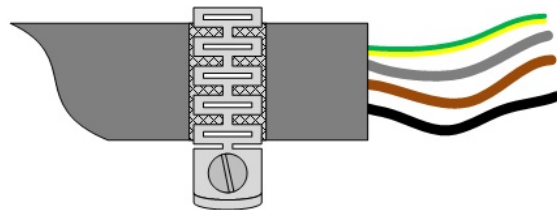

- Flanges to fold (in door frame box only)

Press the cable to the plate, fold the flange on the shield, and screw it in the holes dedicated:

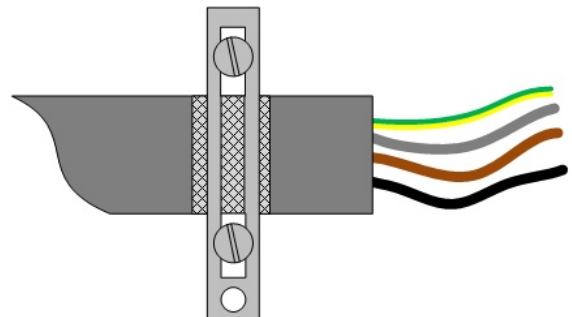

## Temporary box

### ATTENTION



Temporary box bypasses all the safety chain and shall be used during lift's mounting step only, under skilled and authorized technicians control.

### NOTE

As the safety chain is not plugged onto 405 board anymore, only the VER led of 400SP board is lit on the closing of the safety chaine by pressing up or down button of the box.

- **With the up & down box**

The Up & Down box may be used to move in temporary operation.

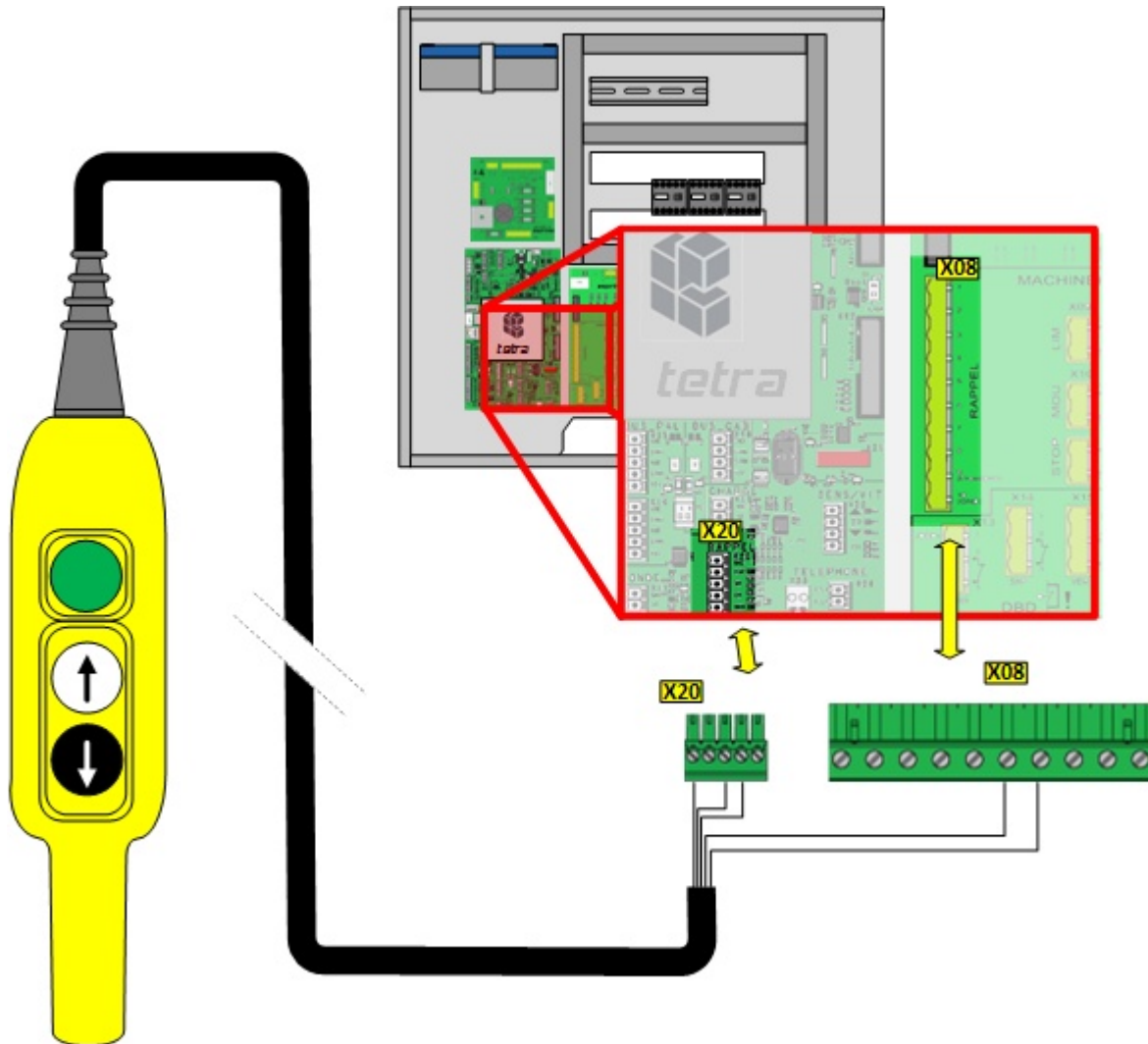

- Plug the connector X20 of the box cable onto 400SP board.
- Plug the connector X08 of the box cable onto 405SP board.

- **With the emergency operation box**

The emergency operation box, together with a specific adaptation cable, may be used to move in temporary operation.

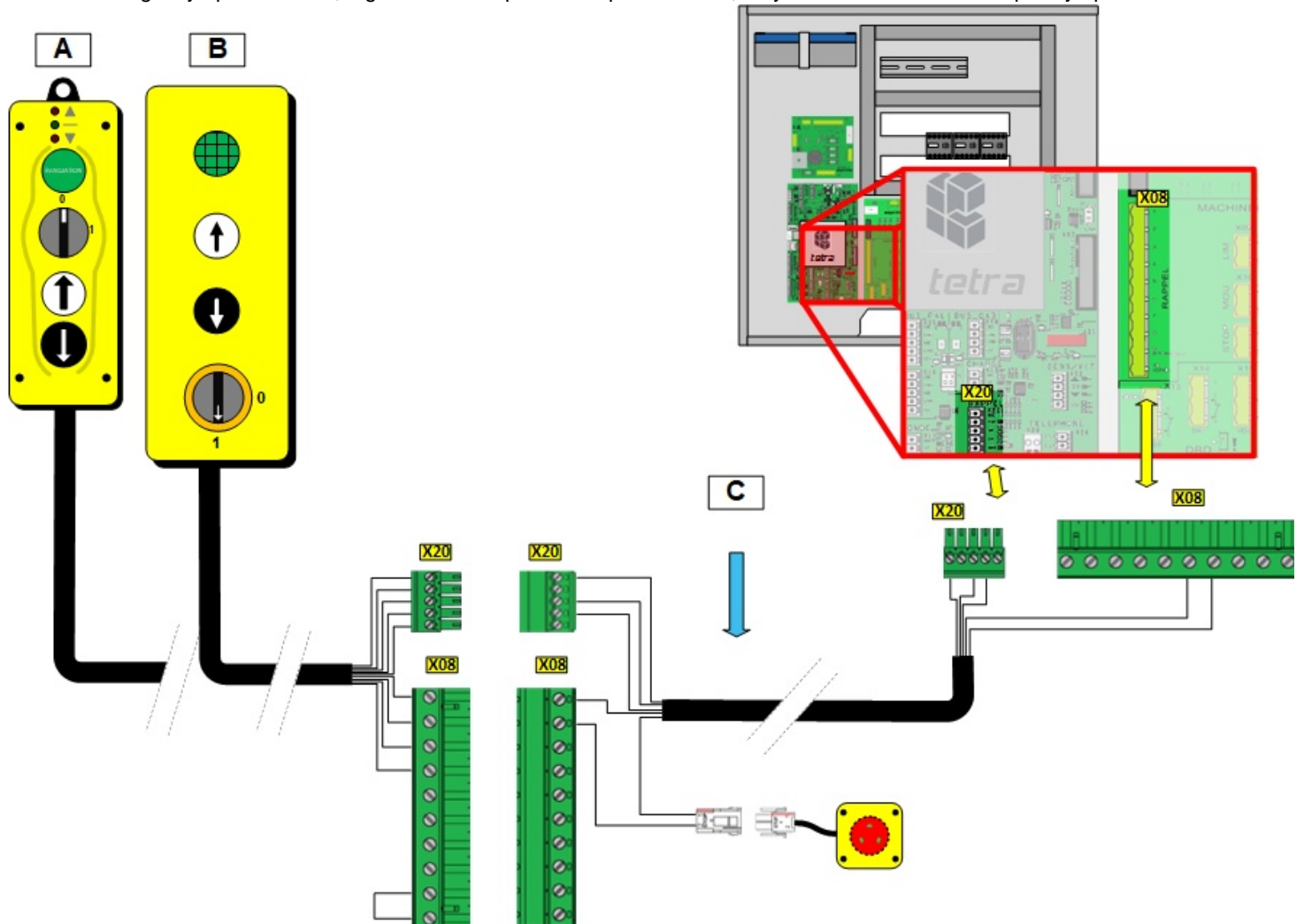

- Plug the emergency operation box (A or B model) onto the reverted connectors of the temporary operation cable (C).
- Plug this temporary operation cable onto 400SP board (X20) and 405SP board (X08)
- Plug the emergency stop device intended for the pit onto the dedicated connector of this cable

## Motor's datas and auto-tuning

The auto-tuning of the motor is a mandatory step to move the car electrically. Perform this step in temporary or electrical emergency operation

### NOTE

Use the *Sprinte Control app* on the tablet to perform the commissioning steps

- Go into the **CUSTOMIZATION EQUIPMENTS HOIST MOTOR** menu.

### PARAMETERS FOR A GEARLESS MACHINE, WITH SYNCHRONOUS MOTOR

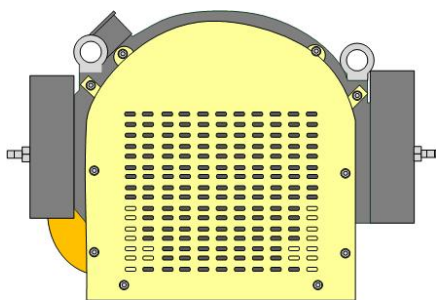

### PARAMETERS FOR A GEARBOX MACHINE, WITH ASYNCHRONOUS MOTOR

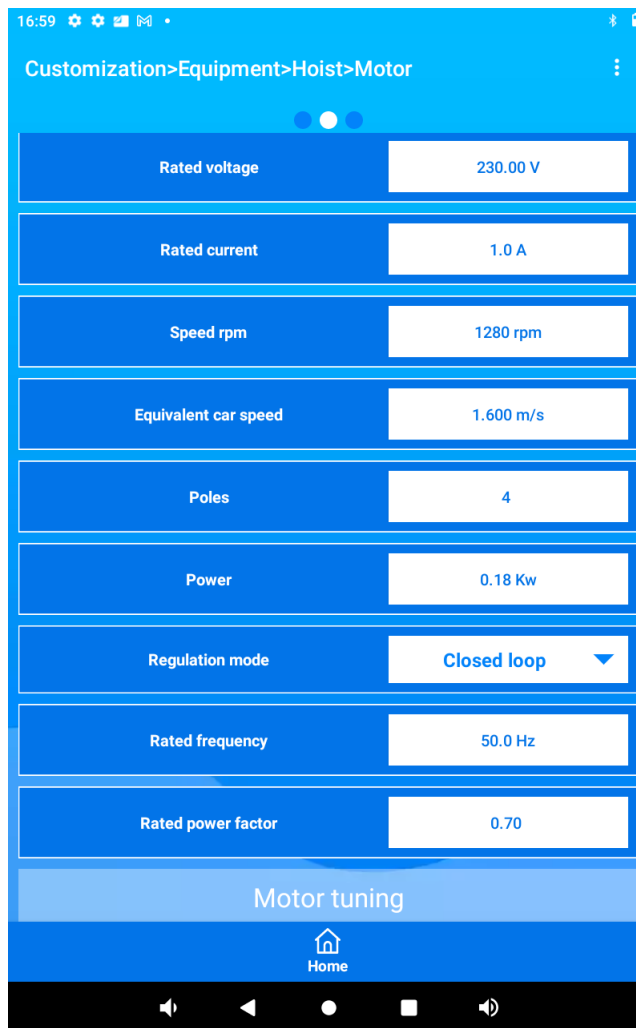
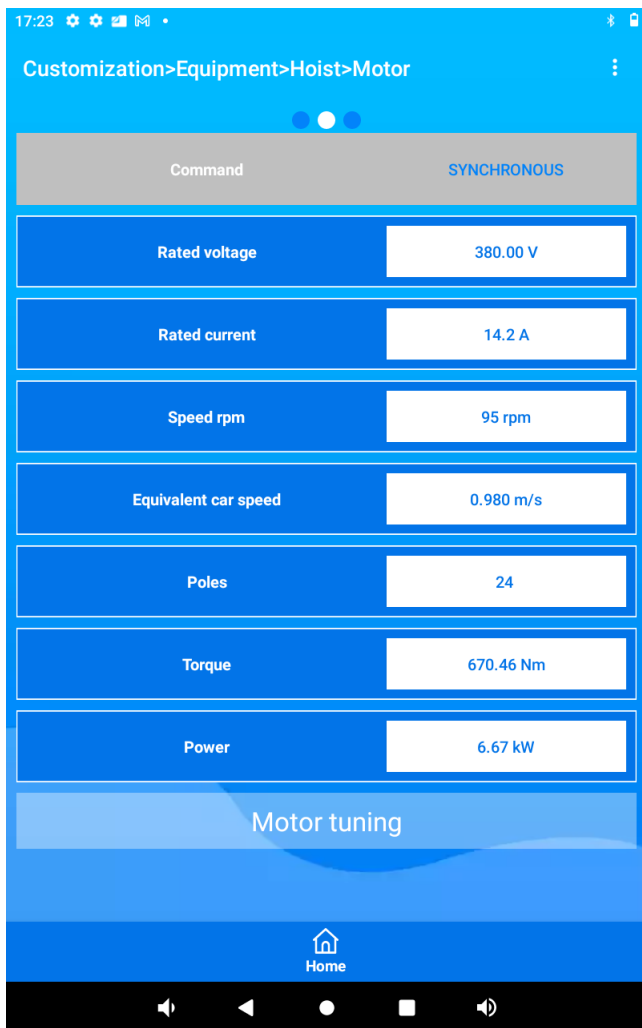
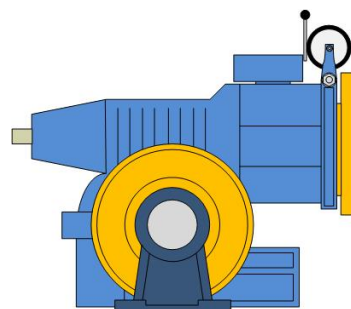

Fill in the following parameters according to the motor plate :

- Rated voltage**
- Rated current**
- Speed rpm**

**NOTE**

For an asynchronous motor only:

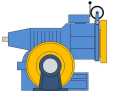

If the rated speed is 1500rpm, you have to enter the value **1380** rpm to consider the motor slippage

○ **Equivalent cabine speed**

This speed is the moving speed of the cabine if the motor runs at its maximum speed, it has nothing to do with the rated speed of the lift. The value may so be higher than the rated speed of the lift

○ **Poles**

The motor plate indicates sometimes plaque moteur "Poles pairs". In that case, double the value indicated, and enter the result here.

**REMARQUE**

If the poles number is not indicated on the motor plate, it can be computed as below :

**$Poles = (Frequency \times 60 / Speed) \times 2.$**

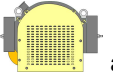
Example for a synchronous motor  at **200 rpm** at **40 Hz.** ,

Poles =  $(40 \times 60 / 200) \times 2 = 24.$

Example for an asynchronous motor  at **1500 rpm** at **50 Hz.:**

Poles =  $(50 \times 60 / 1500) \times 2 = 4.$

○ **Torque**

○ **Power**

Motors plates don't give always torque and power; but both parameters are linked to with the speed

If you fill in the torque value, power will be automatically computed, and vice-versa, if you fill in the power value the troque will be automatically computed.

For an asynchronous motor, the additional parameters below have to be set :

○ **Rated frequency**

○ **Cos phi**

- Motor datas are filled in, now the motor tuning has to be done

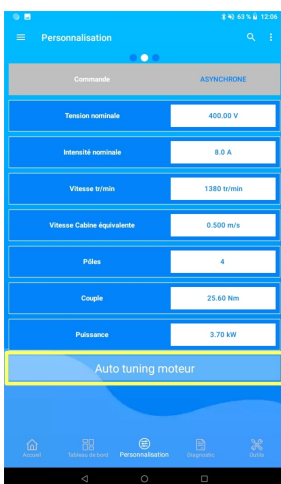

Press **RUN TEST** button to start the tuning process; the steps below follow then



The controller checks the potential faults of the frequency inverter in order to launch the tuning

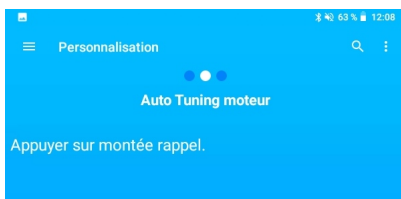

The inverter needs the validation with safety chain to power the motor and perform the tuning. By pressing "Up" button, the safety chain is closing

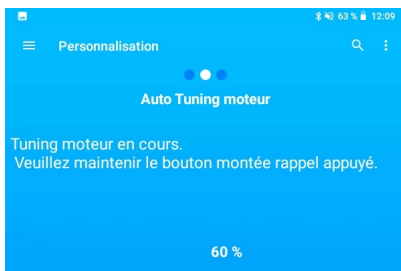

Once the safety chain is closed, the tuning starts; it can last over one minute, keep the button pressed or the safety chain will open and the tuning process will be cancelled

## NOTE

*The autotuning of a gearless motor is long and very noisy, this is completely normal*



Once the tuning is over, you can release the "Up" button

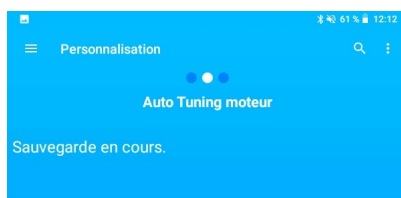

Motor tuning's datas are saved inside the inverter

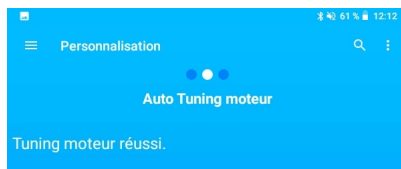

Motor tuning has been properly done, press END button to continue the lift installation

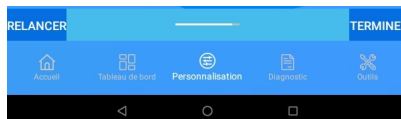

## Encoder's datas and auto-tuning

The auto-tuning of the motor's encoder is also essential to move the car electrically. Perform this step in temporary or electrical emergency operation

- Go to the **CUSTOMIZATION EQUIPMENTS HOIST ENCODER** menu

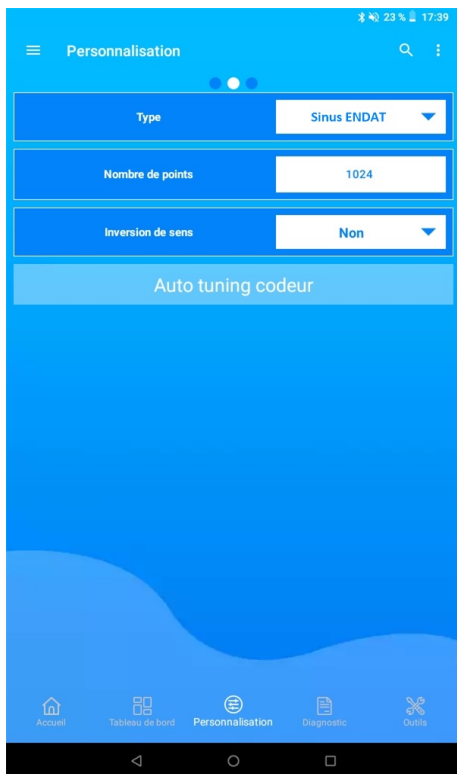

Fill in the following parameters according to the encoder characteristics :

- Type**
- Pulses number**
- Direction inversion**

The direction inversion has to be changed, if during the motor doesn't rotate or rotates in the wrong direction, (see [Step 5](#) further)

- Encoder's datas are now filed, now its autotuning has to be performed

### IMPORTANT

This step is **necessary** only for **synchronus motors**  
Skip this step in case of asynchronous motor.

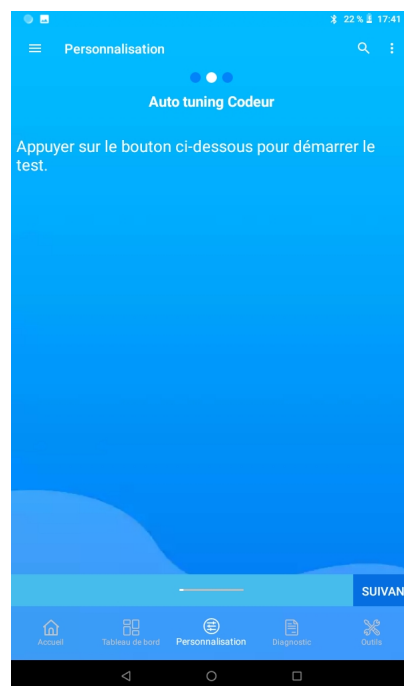
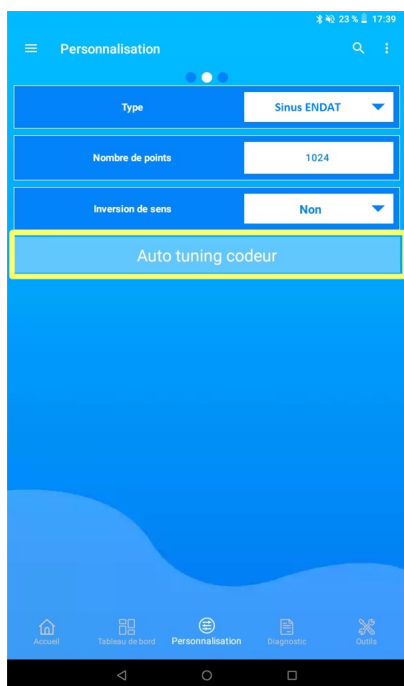

Press **RUN TEST** button to start the autotuning of the encoder, then the steps below follow each other:



The controller checks the potential faults of the frequency inverter in order to launch the tuning

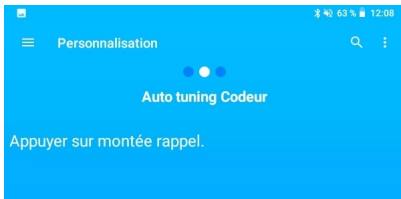

The inverter needs the validation with safety chain to power the motor and perform the tuning. By pressing "Up" button, the safety chain is closing



Once the safety chain is closed, the tuning starts; it lasts only few seconds



Once the autotuning is over, you can release the "Up" button

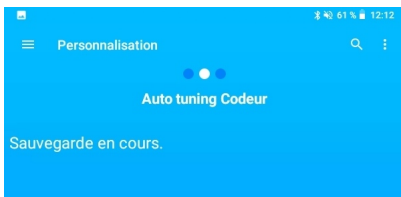

Autotuning data is saved in the inverter

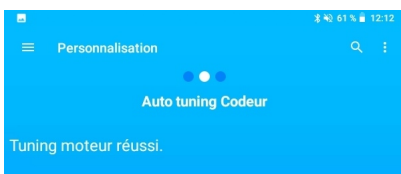

Autotuning has been properly done, press END button to continue the lift installation

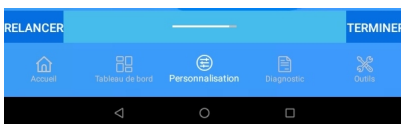

## Checking the movement

You have now to check that the motor is running properly and in the right direction. Use the temporary box or the emergency operation panel to move the car

- If the motor is running upside down, or doesn't run at all, the encoder phases have to be revert in the inverter  
Go back in the menu **CUSTOMIZATION** ➔ **EQUIPEMENTS** ➔ **HOIST** ➔ **ENCODER** :

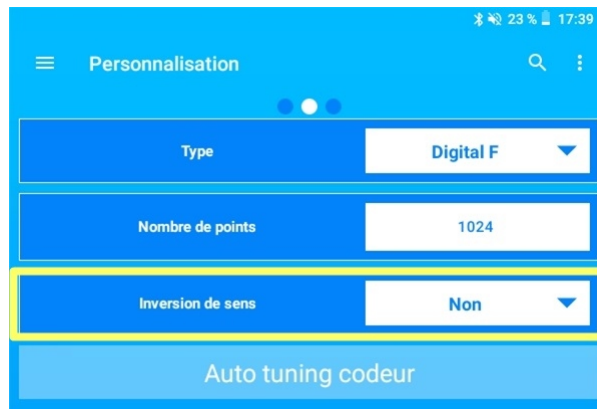

Switch the value **NO** to **YES**, of **Direction inversion** parameter, and restart the encoder autotuning (see [Step 4](#) above)

- If the motor is running properly but upside down, it is mandatory to
  - Revert the wiring of phases U and V on the inverter terminal (see [motor wiring](#) chapter)
  - Revert once again the encoder phase as mentioned above, and run once again the autotuning (see [Step 4](#) above)

**ATTENTION**



*Each time the parameter **Encoder Direction** is modified , it is mandatory to perform the autotuning of the encoder(see step 4)*

## Shaft positioning system

### Kit contents

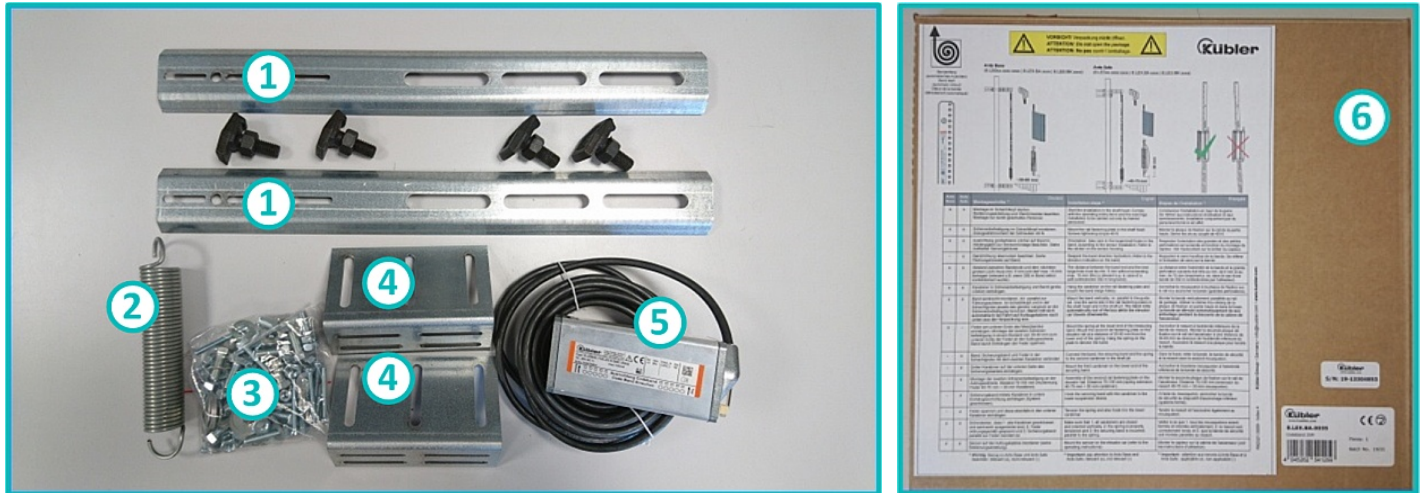

1. Rail fastening plates for the tape (x2) and clamping plates (x4)
2. Tension spring for the tape
3. Screws, bolts and nuts kit
4. Fixing bracket for the reader (x2)
5. Absolute reader case
6. Stainless steel encoded tape

#### NOTE

Before any mounting operations, note the fixture direction of the reader on the car

#### Right mounting :



#### Wrong mounting:



## Mounting of the tape

### NOTE

Before installing the tape, think of the correct insertion in the reader

Right insertion :



Wrong insertion:

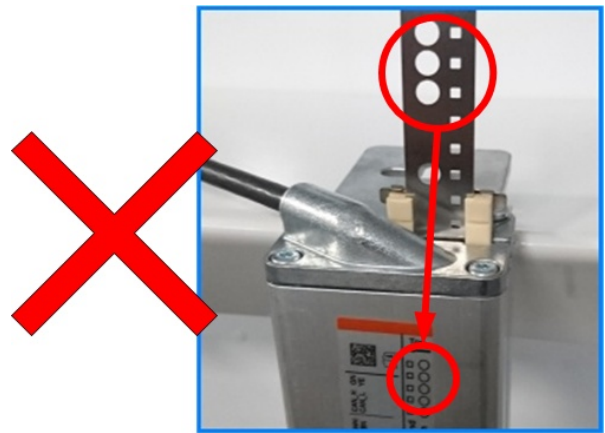

- Fix the first fastening plate for the band at the top of the rail with the clamping plates provided :



- With M5 screw, nut and washer, fix the band on the fastening plate while making a loop :



- Unroll the tape down to the bottom, keeping it in its box.

- Fix the second fastening plate for the band at the bottom of the rail with the clamping plates provided :



- Hang on the tension spring on this plate (keep 3cm to 6cm of tension between spring and plate), and block it with M5 screw, nut and washer :

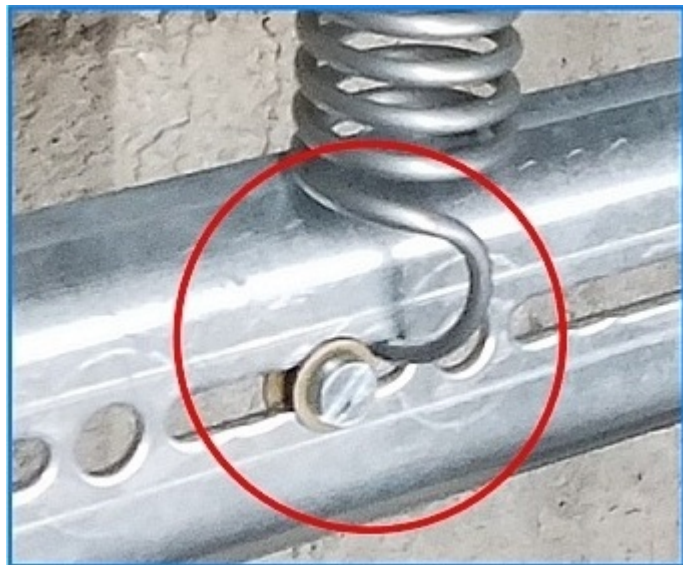

**NOTE**

*Take care to install the tape as vertically as possible*

## Mounting of the reader

- Set together the fixing brackets on the car's roof, then fix the reader upon without a hard tighten for adjustment when inserting the tape:



- Gently bend the metallic tab (1) then remove the slide from the top (2). Insert the tape et replace the slide.

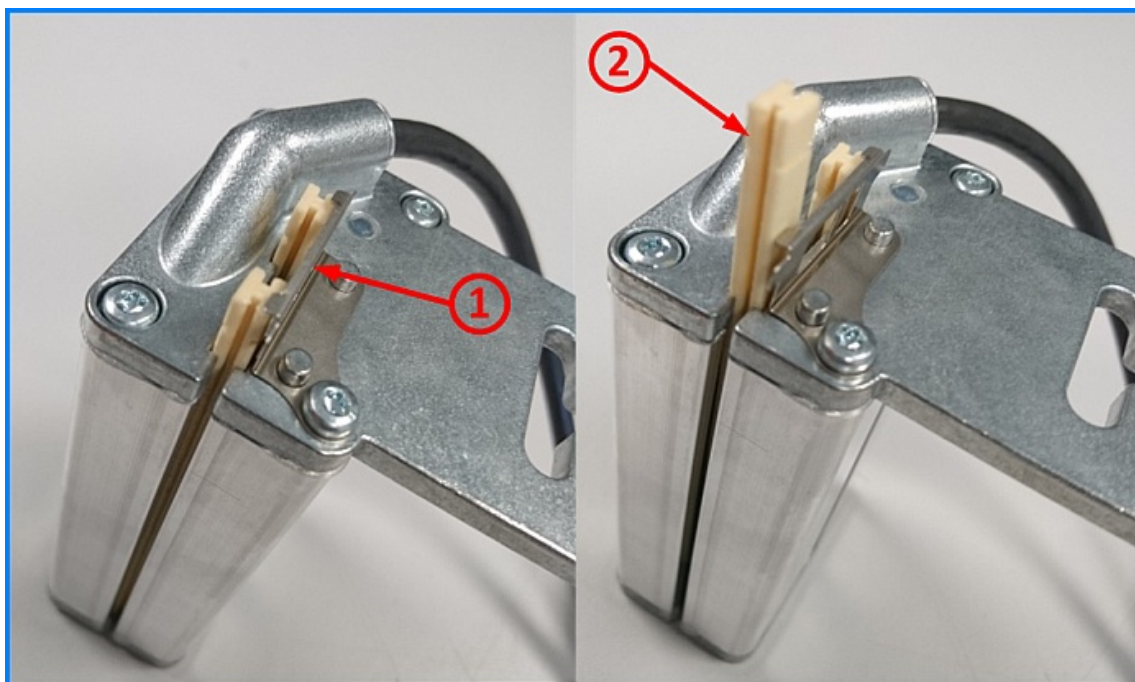



### NOTE

*Check the presence of second slide before inserting the band*

- Adjust the reader in order to avoid any deformation or twisting of the band, then hard tightened it on the fixing brackets.

## Shaft's learning phase

Shaft's learning phase has to be performed in inspection mode from the car's roof.

To launch it, push together Up  and Down  buttons of the inspection box, and just follow the vocal instructions

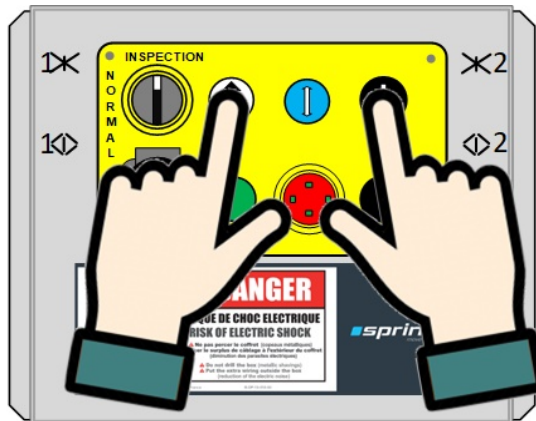

Once the shaft's learning phase is over, you can visualize the heights recorded for each in the menu : **CUSTOMIZATION EQUIPMENTS SHAFT READER FLOORS HEIGHTS :**



### IMPORTANT

From the top of the car it's very difficult to record the height of the car matching precisely the ground of each floor; You will have to correct these heights from the menu pictured above

But before correct these heights, it is essential to fix the stopping accuracy of the regulation machine (VF, Hydraulics...); i.e. the car has stopped precisely at the height requested.

Strictly follow the order of the two steps below, described in the next chapters :

- Regulation stopping accuracy.
- Floors adjustment.

## Regulation stopping accuracy

This chapter details how to adjust the stopping accuracy of the regulation, i.e. reach as close as possible the desired position.

For that, strictly follow the order of the following steps :

- **MOVING SPEEDS**

You must first adjust the different speeds of the lift.

- Go into menu **CUSTOMIZATION EQUIPMENT TRACTION SPEEDS :**

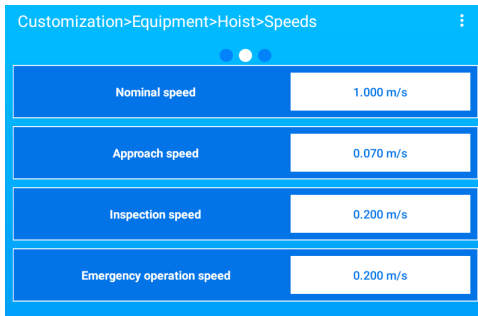

Customization>Equipment>Hoist>Speeds	
Nominal speed	1.000 m/s
Approach speed	0.070 m/s
Inspection speed	0.200 m/s
Emergency operation speed	0.200 m/s

- The **Nominal speed** corresponds to the contract speed of your lift.
- The **Approach speed** is the speed instruction used to slow down in Velocity Profile.
- The **Inspection speed** may be set up to 0,63 m/s maximum.
- The **Emergency operation speed** may be set up to 0,3 m/s maximum.

**NOTE**

*The **Approach speed** is irrelevant in Smart Travel, it isn't displayed if the Smart Travel is the movement profile selected*

- **REGULATION CORRECTION**

You have next to adjust the fundamentals parameters of the regulation loop in order to correct the behavior of the motor when starting and when moving.

**IMPORTANT**

This step necessary only if the motor is in **CLOSED LOOP** regulation motor regulation.  
Skip this step if the lift is equipped with an asynchronous open loop motor.

- First, go into **CUSTOMIZATION EQUIPMENT TRACTION GAINS:**

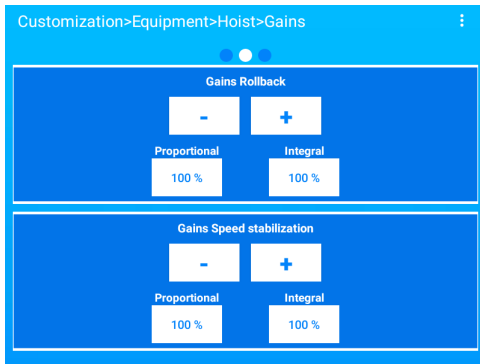

**NOTE**

Keys and are used to increase or decrease proportional and integral gains together by step of 20%. By pressing directly on the value of a gain you can modify it independently

- **Rollback** parameter allows to adjust vibration or rollback problems on start  
On a start upward or downward of the lift :
  - if there is rollback , increase both gains
  - if there are vibrations, decrease both gains
- **Speed stabilization** parameter allows to adjust vibration or fluctuation of the speed while moving.  
During a movement of the lift upward or downward :
  - if there are fluctuations , increase both gains
  - if there are vibrations, decrease both gains.

## MOVEMENT PROFILE

You have now to select and adjust the movement profile of the car, in order to ensure its proper positioning on each floor. Two profiles are available :

- Smart Travel.
- Velocity profile

The choice of the profile and its settings are in the menu :

**CUSTOMIZATION EQUIPMENTS HOIST MOVEMENT PROFILE**

- **SMART TRAVEL**

<b>NOTE</b>	<i>Smart Travel is available only in case of closed-loop motor regulation (e.g. with an encoder) and an absolute position reader in shaft (K05SP or K06SP).</i>
-------------	---

Smart Travel sends the car to the floor using only floor heights:

To reach a floor, the controller sends the floor height value to the inverter drive, which computes automatically the travel curve, as shown in the figure below:

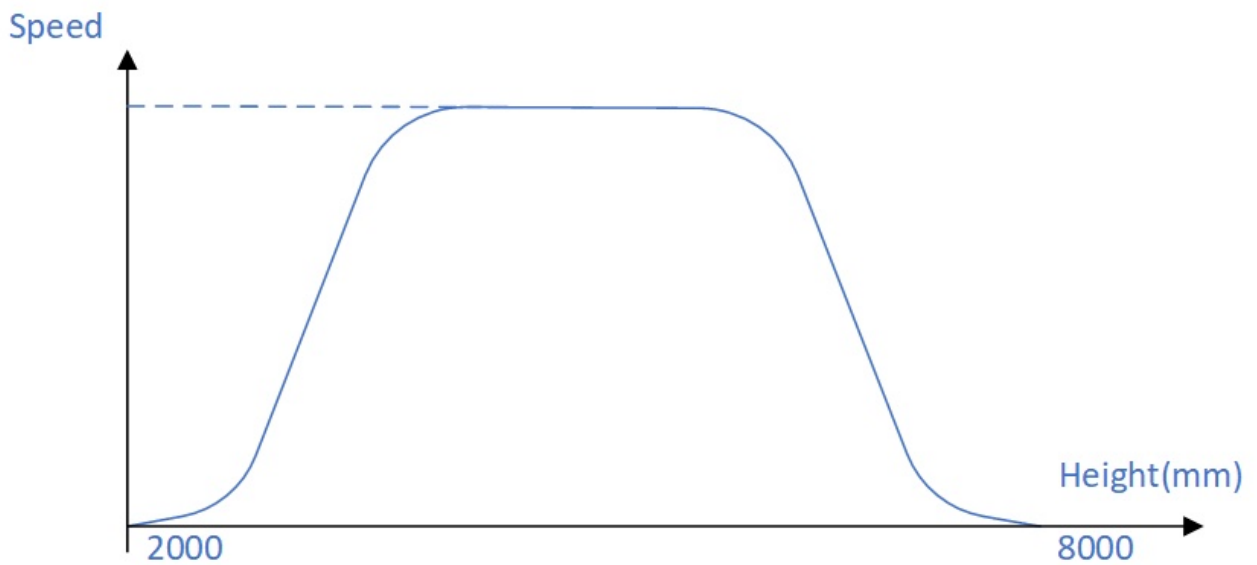

The stopping accuracy is determined by the distance between the destination floor height value saved and the real position of the car when arrived at this floor.

Use the informations on the dashboard of the Sprinte Control application to check this stopping accuracy.

### CURRENT FLOOR

Here is displayed the floor where the car is located, and also its height valued saved during shaft's learning phase

Car status <b>Available</b> Full <input type="radio"/> Overload <input type="radio"/>	Speed <b>0,00m/s</b>
Current Floor <b>06</b> <b>5,612m</b>	Position      Stopping accuracy <b>5,615m</b> <b>3mm</b> Door zone <input type="radio"/>

### SPEED

Here is displayed the speed of the car computed by the controller

### POSITION

Indicates the exact position of the car

### STOPPING ACCURACY

Displays the distance offset between the car and the height value saved of the floor.

In Smart travel, if the stopping accuracy is not correct, the inverter doesn't move the car at the expected speed. Set the parameter **Equivalent car speed** to reach the correct speed et get a good stopping accuracy.

The **Equivalent car speed** parameter is the supposed speed which the car will move if the mortar run at its full speed. This **Equivalent car speed** is not the nominal speed of the lift, its value thus may be higher.

This parameter is available in menu **CUSTOMIZATON EQUIPMENTS HOIST MOTOR**



- Perform different travels in upward and downward direction
- Check at each stop in the **STOPPING ACCURACY** frame that it's between -2mm and +2mm.
  - If the car stops above +2mm in upward direction or -2mm in downward direction , it has been stopped too late; the **Equivalent car speed** must be increased (0,02 by 0,02)...
  - If the car stops below -2mm in upward direction or +2mm in downward direction , it has been stopped too early; the **Equivalent car speed** must be decreased (0,02 by 0,02)...

## ○ VELOCITY PROFILE

The velocity profile is a positioning of the car by decreasing speed instructions (nominal speed, approach speed, stop), as shown in the figure below

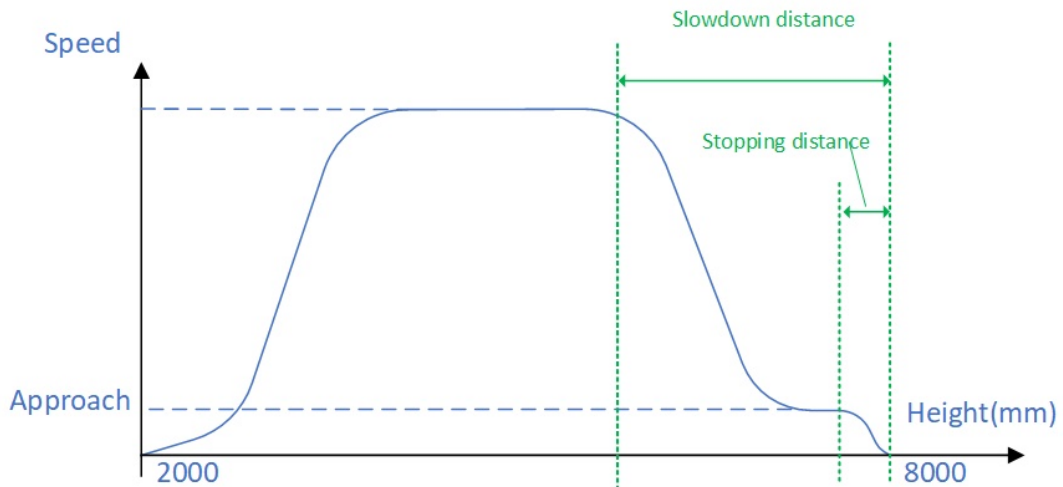

At start, the **Nominal speed** is applied, then, when the **Slowdown distance** is reached, the **Approach speed** is applied. Finally when the **Stopping distance** is reached, a stop command is applied.

To reach a proper stopping accuracy, you have to adjust the values of these distances.

These settings are available in the menu **CUSTOMIZATION EQUIPMENTS HOIST MOVEMENT PROFILE :**

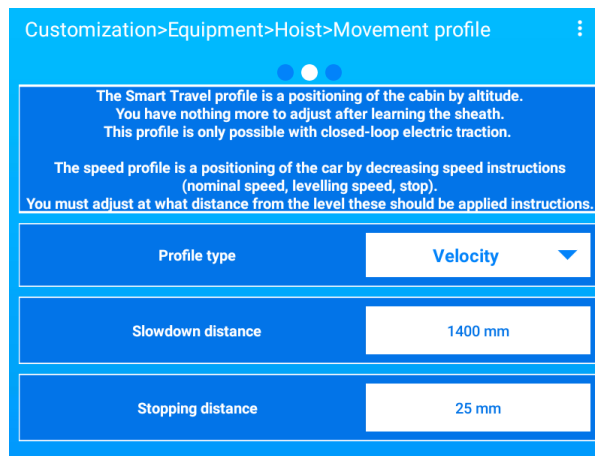

The table below gives usual values for **Slowdown distance**, **Approach speed** and **Stopping distance** according to the **Nominal speed**.

Nominal speed	Slowdown distance	Approach speed	Stopping distance
0,4 m/s	550 mm	0,08 m/s	25mm
0,6 m/s	800 mm		
0,8 m/s	1 100 mm		
1 m/s	1 300 mm		
1,2 m/s	1 600 mm		
1,4 m/s	2 000mm		
1,6 m/s	2 200mm		

To check this stopping accuracy; use the indications of speed and position displayed on the dashboard of the Sprinte Control application.

## CURRENT FLOOR

Here is displayed the floor where the car is located, and also its height valued saved during shaft's learning phase

<p>Car status</p> <p><b>Available</b></p> <p>Full <input type="checkbox"/> Overload <input type="checkbox"/></p>	<p>Speed</p> <p><b>0,00m/s</b></p>
<p>Current Floor</p> <p><b>06</b></p> <p><b>5,612m</b></p>	<p>Position</p> <p><b>5,615m</b></p> <p>Door zone <input type="checkbox"/></p>

## SPEED

Here is displayed the speed of the car computed by the controller

## POSITION

Indicates the exact position of the car

## STOPPING ACCURACY

Displays the distance offset between the car and the height value saved of the floor.

- Perform different travels in upward and downward direction
- At each slow down, check on the in the **SPEED** frame , that the **Approach speed** is maintained for 2s.
  - If the car doesn't maintain the **Approach speed**, it has slowed down too late; the **Slowdown distance** must be increased.
  - if the car maintains the **Approach speed** more than 2s, it has slowed down too early; the **Slowdown distance** must be decreased
- Once the the **Slowdown distance**.is properly set, check at each stop in the **STOPPING ACCURACY** frame that it's between -2mm and +2mm.
  - If the car stops above +2mm in upward direction or -2mm in downward direction , it has been stopped too late; the **Stopping distance** must be increased.
  - If the car stops below -2mm in upward direction or +2mm in downward direction , it has been stopped too early; the **Stopping distance** must be decreased.

## NOTE

*In case the stopping accuracy is correct in the first direction, but not in the opposite direction, you can set a different stopping direction for upward and downward direction, by enabling the expert mode in the Sprinte Control app.*

## • SETTINGS FOR HIGH-SLIP MOTOR

### IMPORTANT

This step is necessary only if the motor is in **OPEN LOOP** regulation you are unable to obtain correct and repeatable stopping accuracy.  
Skip this step if the lift is equipped with an closed loop motor.

- First, go into **CUSTOMIZATION EQUIPMENT TRACTION MOTOR U/F:**



- Switch the application in expert mode by pressing the 3 points on up right corner of the screen

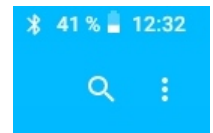

- The default mode is basic mode

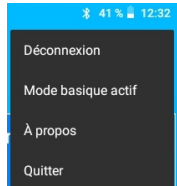

- Press the basic mode line to switch to expert mode

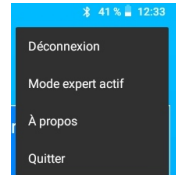

- Access to **Middle Voltage** setting and add **20V** to the current value :



- Then, access to **Profile type** setting and change it to **Customized** value.

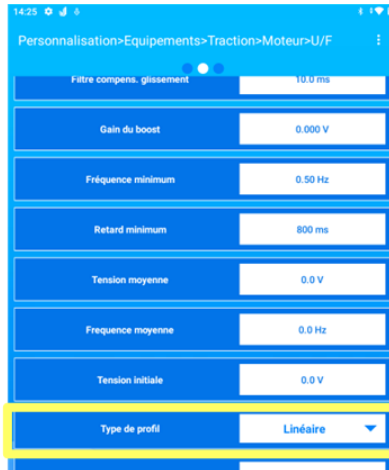

- Perform new travels of the cat. If the stopping accuracy is still not good, in the same menu, access to **Slip Comp Hold** setting and change it to **Enabled** value.

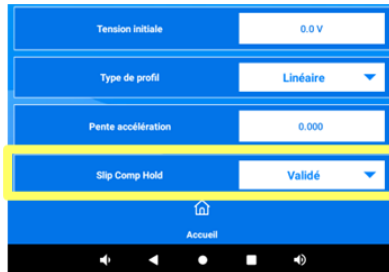

## NOTE

After new travels of the car, if the stopping accuracy is definitely present, then contact our after-sales department ( see contact on cover page).

## Floors adjustments

You have now to check and correct for each level, the alignment of the ground of the car with the ground of the floor.

### IMPORTANT

*This step of floors adjustment shall be done only if you have performed the stopping accuracy step before (see previous chapter).*

Send the car to each floor and measure the step from the ground of the car to the one of the floor. Fix then the height value saved according to your measurement.

The heights values saved can be modified in the menu

**CUSTOMIZATION EQUIPMENTS SHAFT READER FLOORS HEIGHTS :**

### NOTE

*If the stopping accuracy displayed is different from zero, it has to be considered in the new value of the floor height. Use the indications on the dashboard to know the stopping accuracy value*

Below are some examples of corrections to apply with different stopping accuracies :

In all those examples :

- The blue line represents the height value currently saved for the floor
- X The black number represents your measurement of the distance between car and floor.
- X The blue number represents the stopping accuracy display on the dashboard
- X The red number represents the correction that has to be set to height value saved.

Current Floor!	Position	Stopping accuracy
04	4,402m	0mm
4,402m		Door zone

### • EXAMPLE WITH A STOPPING ACCURACY OF +0MM

- Car above the floor:

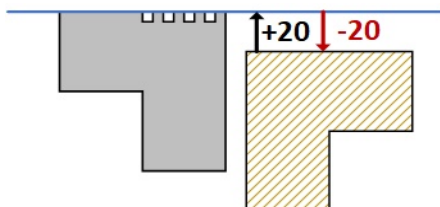

The car is **20mm above** the ground of the floor.

You have to **subtract 20mm** to the height value saved

- Car below the floor

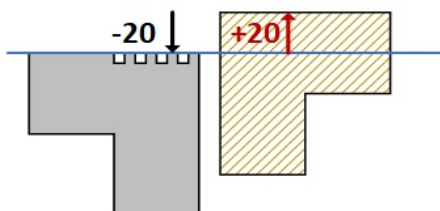

The car is **20mm below** the ground of the floor.

You have to **add 20mm** to the height value saved.

Niveau actuel	Position	Précision d'arrêt
06	5,615m	3mm
5,612m		Zone de positionnement

● EXAMPLE WITH A STOPPING ACCURACY OF +3MM

○ Car above the floor:

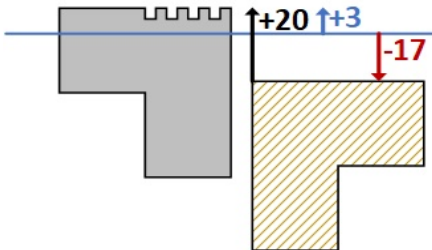

The car is **20mm above** the ground of the floor.,  
As the car stopped **3mm** higher than expected,  
you have so to **subtract only 17mm** to the height value saved.

○ Car below the floor:

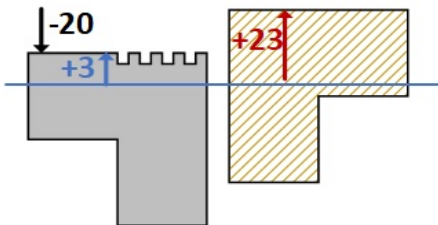

The car is **20mm below** the ground of the floor  
As the car stopped **3mm** higher than expected,  
you have so to **add 23mm** to the height value saved.

Current Floor	Position	Stopping accuracy
00	1,999m	-1mm
2,000m		Door zone

● EXAMPLE WITH A STOPPING ACCURACY OF -1MM

○ Car above the floor:

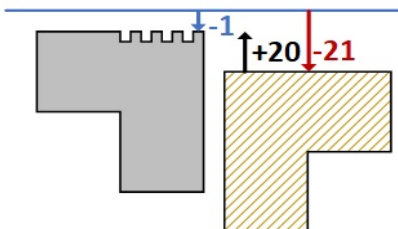

The car is **20mm above** the ground of the floor.,  
As the car stopped **1mm** lower than expected,  
you have so to **subtract 21mm** to the height value saved.

○ Car below the floor:

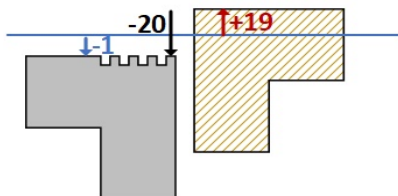

The car is **20mm below** the ground of the floor  
As the car stopped **1mm** lower than expected,  
you have so to **add only 19mm** to the height value saved.

## Relevelling

The relevelling and leveling (early opening of the door) operations allow the movement of the car with the doors open only in the door's unlocking zone.

This movement with doors open is performed through a safety relay which closes to bypass the doors safety contacts and reopens as soon as the car leaves the unlocking zone, materialized by a 30cm long magnet.

The need to integrate the levelling/relevelling functions is determined by the lift manufacturer.

## Sensors installation

The safety relay is already placed and wired in the car inspection box. You have to fix the sensors and place all the magnets materializing the unlocking door zones

- On the car roof, install the magnet sensors side by side, facing a rail guide, using the kit delivered (see below)
- Connect the magnet sensors on X11 terminal of 415SP board (see wiring diagram).
- For each level, place the car at the position of the landing and place the magnet on the rail guide, centered in front of the magnet sensors

### NOTE

*The sensors and the magnets shall not be distant more than 10mm*

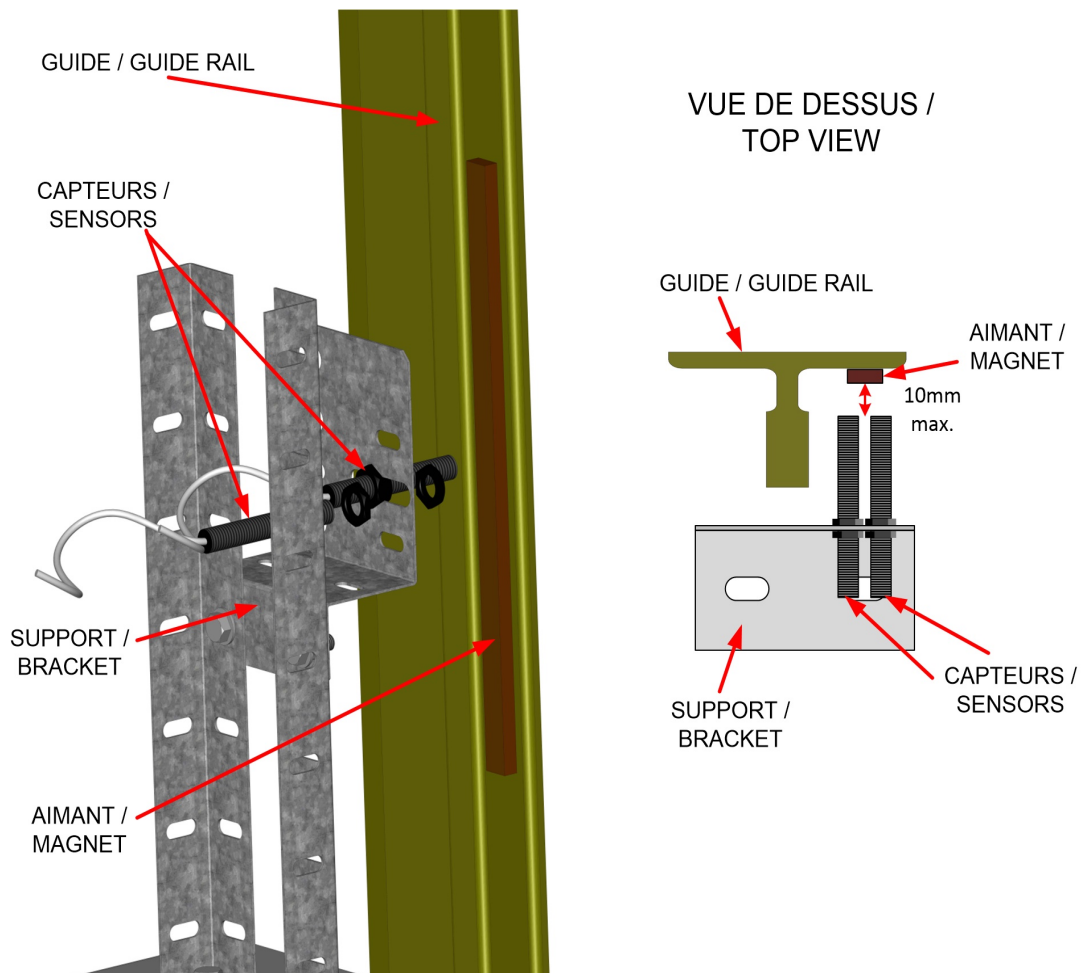

### IMPORTANT

*The safety relay is a part of the protection device against unintended car movement, as it fulfills the detection function.*

*Thus it has to be check on commissioning and at each maintenance visit.*

*Use for that purpose the **Relevelling test** documented in Annex A9 of this manual*

## Electrical synoptics

### CAN buses architecture

For the proper operation of the controller, the CAN buses lines have to be terminated at each end. On every electronic board of the Tetra's controller which is connected to a CAN bus, a dip switch enables or disables a 120ohms termination resistance.

But according to the machine room location, these are not the same boards that are connected at the end of the CAN bus.

- CASE OF A MACHINE ROOM AT THE TOP

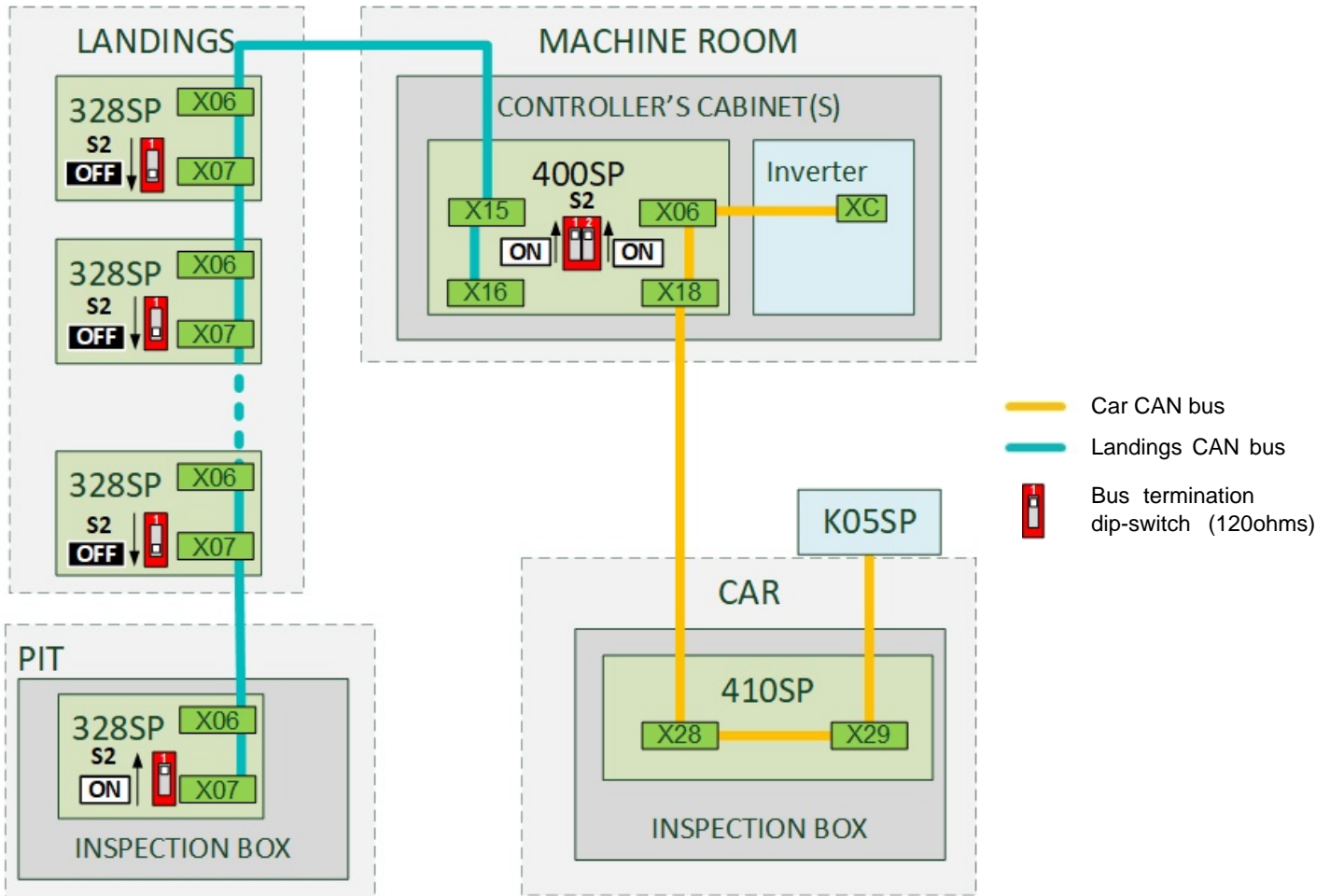

- CAR BUS

The inverter and K05SP reader are always connected at the end of the CAR bus line.

K05SP integrates a 120ohms termination resistance, the bus is then properly closed on its side.

The inverter doesn't integrate a resistancen, thus the S2-2 dip-switch on 400SP board has to be set to ON to close the bus line on this side.

- LANDINGS BUS

The 400SP board and the 328SP pit inspection board are connected to both ends of the landing CAN bus line.

Thus the S2-1 dip-switch of 400SP and S2 dip-switch of the 328SP inspection board have to be set to ON to close the line on both ends.

The dip-switches of all of the 328SP landing boards have to be set to OFF.

• CASE OF A BOTTOM MACHINE ROOM :

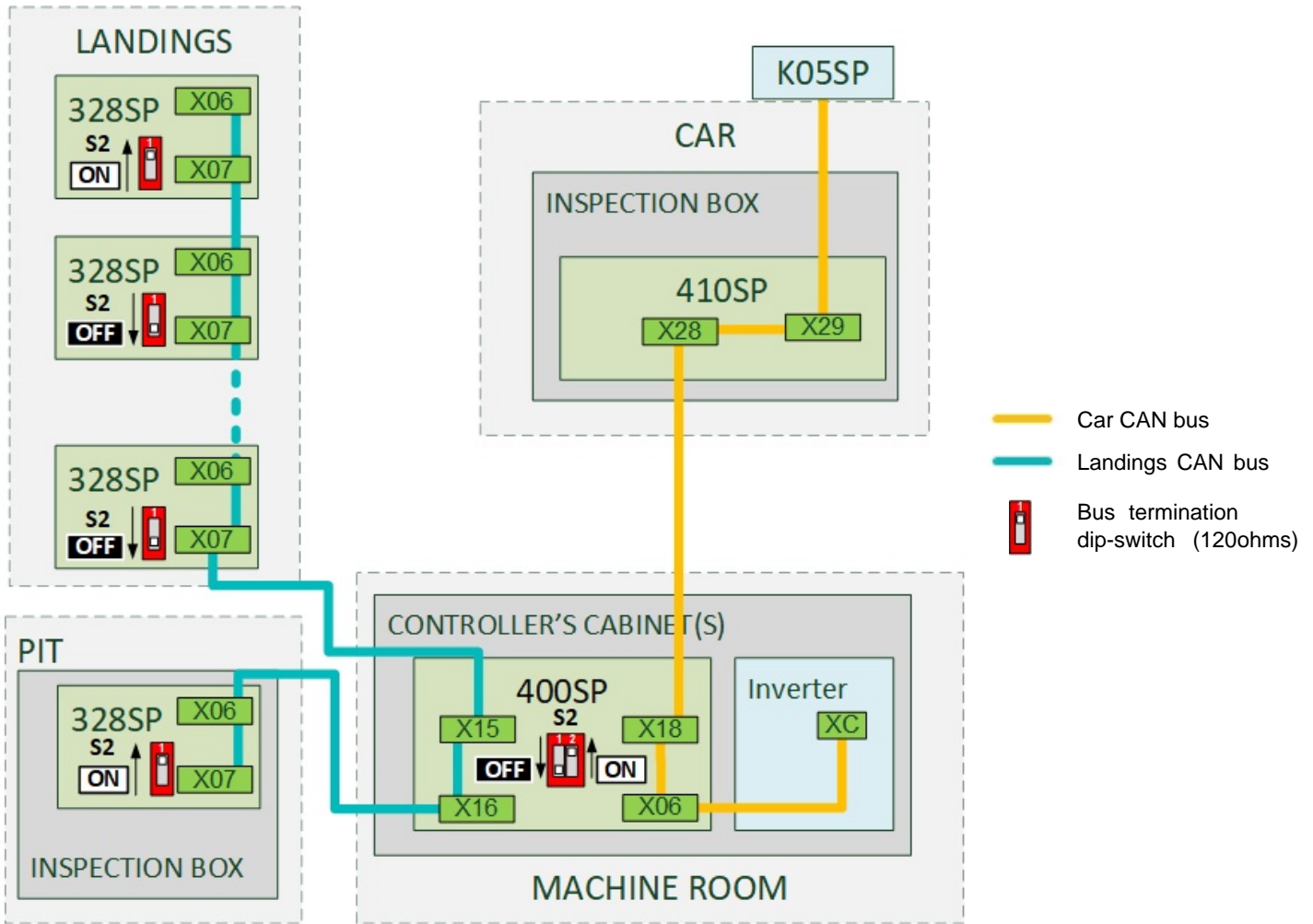

○ CAR BUS

The inverter and K05SP reader are always connected at the end of the CAR bus line.  
 K05SP integrates a 120ohms termination resistance, the bus is then properly closed on its side.  
 The inverter doesn't integrate a resistancen, thus the S2-2 dip-switch on 400SP board has to be set to ON to close the bus line on this side.

○ LANDINGS BUS

The 328SP board of the last floor and the 328SP pit inspection board are connected to both ends of the landing CAN bus line.  
 Thus the S2 dip-switch these two boards have to be set to ON close the line on both ends.  
 The dip-switches of all other 328SP landing boards and the dip-switch S2-1 of the 400SP have to be set to OFF.

## Faults List

This chapter details all faults managed by the controller

The **Diagnosis -> Faults** menu of the Tetra App. displays the chronological list of faults that happened on the lift.

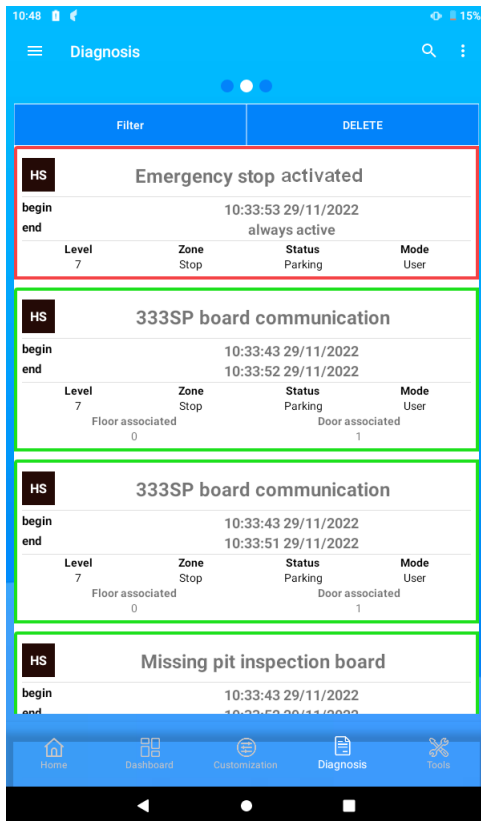

Faults list is detailed in tables as below :

Title	Severity	Description
....	...	...
....	....	....

- **Title** column:

Message as displayed in the application fault menu

- **Severity** Column

Gives severity level of the fault :

**ALR** (Alarm) :  
This fault is a minor failure and doesn't prevent the operation of the lift

**OSU** (Out of service for Users) :  
This fault sets the lift out of order for the users; but the lift keeps operational for technicians mode (inspection and emergency operation)

**OSM** (Out of service maintained) :  
This fault sets the lift out of order; and requests to be cleared by a technician the bring back the lift operational, event if the fault source disappeared.

**OST** (Out of service for Technicien):  
This fault sets the lift out of order for users mode and technicians mode, only temporary operation (for commissioning) is allowed.

**OS** (Out of Service) :  
This fault sets the lift out of order for all modes of the lift.

- **Description** Column :

Detailed explanation of the fault, with possible causes and solutions.

## Power supply faults

Title	Severity	Description
<b>Main power failure</b>	<b>OS</b>	The main power supply of the controller is down <ul style="list-style-type: none"> <li>Check the main breaker DJ1 and the PFS1 fuses.</li> </ul>
<b>24Vdc power supply from grid is missing</b>	<b>OS</b>	The 24Vdc low power supply generated by 404SP board from the grid power supply is missing. All of the electronic boards of the lift controller are powered by the back-up battery although the grid power supply is present. <ul style="list-style-type: none"> <li>Check the 22V fuse (5AT) on 404SP board.</li> <li>Check the power supply connections between 400SP board (X01) and 404SP board (X03).</li> <li>Check the transformer secondary voltage on X05-1 and X05-2 terminals of 404SP board. It has to be around 22 Vac.</li> </ul>
<b>Battery missing</b>	<b>OSU</b>	The backup battery is missing or discharged. In case of main power failure, it will be impossible to fulfill the emergency operation for users. Lift keeps operational for inspection mode
<b>Battery too low</b>	<b>ALR</b>	The backup battery isn't charged enough to ensure the emergency operation up to 1h after a main power failure, as required in chapter 5.9.2.3.1.b of EN81-20 standard
<b>Car light</b>	<b>ALR</b>	The power supply for car light is missing. <ul style="list-style-type: none"> <li>Check DJ2 circuit breaker and DJ1 RCD</li> </ul>
<b>Voltage converter failure</b>	<b>OSU</b>	The voltage converter didn't provide the 230Vac during the emergency operation after a power failure <ul style="list-style-type: none"> <li>Check the wiring of the voltage converter and its ON/OFF switch button</li> </ul>

## Controller faults

Title	Severity	Description
<b>Missing car inspection board Car inspection board communication</b>	<b>OST</b>	The controller can't communicate with 410SP car inspection board <ul style="list-style-type: none"> <li>Check CAN bus connections on controller (X18-400SP) and car inspection box (X28-410SP).</li> <li>Check dip-switch S2-2 of 400SP board, it has to be set to ON.</li> </ul>
<b>Missing pit inspection board Pit inspection board communication</b>	<b>OSU</b>	The controller can't communicate with pit inspection board <ul style="list-style-type: none"> <li>Check CAN bus connections on controller (X16-400SP), on the lowest landing board and in the pit inspection box</li> <li>Check dip-switch S2-1 of 400SP board : It has to be set to ON in case of top machineroom. It has to be set to OFF in case of bottom machineroom.</li> </ul>
<b>328SP LOP board communication (#1 to #32)</b>	<b>ALR</b>	The controller can't communicate with 328SP #xx LOP board <ul style="list-style-type: none"> <li>Check ID number of the 328SP board</li> <li>Check dip-switch S2-1 of 400SP board : It has to be set to ON in case of top machineroom. It has to be set to OFF in case of bottom machineroom.</li> </ul>
<b>Missing VF Drive VF Drive communication</b>	<b>OS</b>	The controller can't communicate with VF Drive <ul style="list-style-type: none"> <li>Check CAN bus connections on the controller (X06-400SP) and the VF drive</li> <li>Vérifiez que le DIP S2-2 de la carte 400SP est positionné sur ON.</li> </ul>
<b>Inverter configuration failure</b>	<b>OS</b>	The controller failed to configure the inverter for the proper operation of the LIFT (I/O, STO function...) <ul style="list-style-type: none"> <li>Check CAN bus connections with the inverter (see above).</li> <li>Then power OFF and ON both controller and inverter (Main power supply circuit breaker)</li> </ul>
<b>Button stuck</b>	<b>ALR</b>	One of the user buttons of the lift is kept pressed longer than 2'30". The information associated to this button (Lift, floor, door) are given in the diagnosis page of the smartphone app.
<b>Stricken floor (0 to 31)</b>	<b>ALR</b>	The lift can't stop anymore on floor X, as the associated fire detector has been activated
<b>Controller clock not set</b>	<b>ALR</b>	Date and time of the controller are not properly set. These information are necessary for the controller to have relevant log event records
<b>Roof SD card missing</b>	<b>ALR</b>	The car's roof board 410SP can't detect the presence of its SD card containing audio files. Vocal announcements can no longer work.
<b>Machineroom overheating</b>	<b>OS</b>	The thermal probe of the machineroom, connected on a 333SP expansion board, indicates an overheating status.

Title	Severity	Description
		<ul style="list-style-type: none"> <li>Check the proper air cooling of the machineroom</li> <li>Check the wiring of the thermal probe on 333SP board, and its trigger setting.</li> </ul>
<b>Missing load weighing device</b>  <b>Load weighing device communication</b>	<b>OS</b>	The controller can't communicate with the load weighing device on the CAN bus <ul style="list-style-type: none"> <li>Check CAN bus connections on the weighing device and on 410SP board (weighing device on roof) or 328SP (weighing device in shaft)</li> <li>Check the setup (EQUIPMENTS LOAD WEIGHING DEVICE) matches the weighing device installed</li> </ul>
<b>Load weighing device setup error</b>	<b>OS</b>	A weighing device is detected on the CAN bus although a wired device is configured in the controller setup. <ul style="list-style-type: none"> <li>Check the setup (EQUIPMENTS LOAD WEIGHING DEVICE) matches the weighing device installed.</li> </ul>
<b>333SP for loading pawl device is missing</b>	<b>OS</b>	The 333SP board used to manage the informations/command of loading pawls is not detected on the CAN Bus by the 400SP controller board. <ul style="list-style-type: none"> <li>Check positions of dips-switches IT1-4 on 333SP board and S2-1 on 400SP board as described in wiring diagram : B-PE-24-057 333SP Boards can bus connections.</li> <li>Check the dips-switches IT1-1 to 3 of 333SP board are set to ON (Up position).</li> </ul>

## Hoist machine faults

Title	Severity	Description
<b>Contactors control at startup</b>  <b>Contactors control at stop</b>	<b>OS</b>	One of the power contactors ( LA, LB, FR , L, LD, ★ or ) is already closed on a startup or has remained closed at a stop. <ul style="list-style-type: none"> <li>Clear the fault (see menu <a href="#">Diagnosis</a> ), and try another movement of the car. If the fault is always detected, replace the external contactor and/or 405SP board</li> </ul>
<b>Contactors control while moving</b>	<b>ALR</b> then <b>OS</b>	One of the electromechanical device that operates the brakes (contactors FR, LA ou LB) didn't close at startup or opened while moving <ul style="list-style-type: none"> <li>Clear the fault (see menu <a href="#">Diagnosis</a> ), and try another movement of the car. If the fault is always detected, replace the external contactor and/or 405SP board</li> </ul>
<b>Traction motor overheating</b>	<b>OS</b>	The thermal probe of the traction motor indicates an overheating <ul style="list-style-type: none"> <li>Check the proper air cooling of the motor</li> <li>Check the wiring of the thermal probe (X17-400SP, see <a href="#">Câblage de la sonde</a>)</li> </ul>
<b>Maximum moving time reached</b>	<b>OSU</b>	The travel exceeded the maximum time allowed, as required by EN81-20 standard in chapter 5.9.7.2 Le déplacement a dépassé la durée maximum autorisée, conformément à l'exigence 5.9.2.7.2 de la norme EN81-20. <ul style="list-style-type: none"> <li>Check the traction cables don't slip on the pulley</li> <li>Check the nominal speed setting.</li> </ul>
<b>Wrong moving direction</b>	<b>ALR</b> then <b>OSU</b>	The moving direction of the car is in the opposite direction to that ordered to the VF drive <ul style="list-style-type: none"> <li>Check the wiring of the motor phases and the motor encoder (see <a href="#">Motor wiring</a> )</li> </ul>
<b>No car movement detected</b>	<b>OSM</b>	On a travel order, the car didn't move for a time longer than the anti skidding timer. The lift shall be set out of order until the intervention of a technician as required in chapter 5.9.2.7.1 a) of EN81-20 standard <ul style="list-style-type: none"> <li>Check the suspension means, power supply of the motor, and the shaft reader.</li> </ul>
<b>Stopping accuracy</b>	<b>ALR</b> then <b>OSU</b>	The car stopped beyond the stopping area when arriving at floor. If it occurs on 5 consecutive travels , the lift is set out of order. <ul style="list-style-type: none"> <li>Check that the stopping distance set is not too short.</li> <li>Check that the slowing distance set is not too short (used in case of speed profile, flags reader or hydraulic lift).</li> </ul>
<b>Car sliding</b>	<b>OSU</b>	The car stopped beyond the door unlocking area when arriving at floor. If it occurs on 5 consecutive travels , the lift is set out of order. <ul style="list-style-type: none"> <li>In case of a flags reader, check that the screen for door area is properly placed.</li> <li>Check that the slowing distance set is not too short (used in case of speed profile, flags reader or hydraulic lift).</li> </ul>

## Electric hoist machine faults

Title	Severity	Description
<b>Brakes control alarm</b>	<b>OSM</b>	<p>The safety brakes didn't raise for a start, or didn't release after a stop</p> <ul style="list-style-type: none"> <li>Check the wiring of the brakes contact on the VF drive (see <a href="#">Brakes wiring</a>).</li> <li>Check the wiring of the brakes coils on 405SP traction board (X06 &amp; X07, see <a href="#">Brakes coils</a>).</li> <li>Check also the proper configuration of polarity and type of the brakes contact</li> </ul>
<b>SFT1 control at startup</b> <b>SFT1 control at stop</b>	<b>OS</b>	<p>SFT1 feedback input for STO function of the VF drive, is at the wrong state at startup or after a stop.</p> <ul style="list-style-type: none"> <li>Check the input wiring on controller board (X05.2 -400SP and on the VF drive (T3).</li> <li>Clear the fault (see menu <a href="#">Diagnosis</a> ), and try another movement of the car. If the fault is always detected, replace 400SP board and/or the VF drive..</li> </ul>
<b>SFT1 control while moving</b>	<b>ALR</b> then <b>OS</b>	<p>SFT1 feedback input for STO function of the VF drive, is at the wrong state during a movement. If it occurs 5 consecutive times, lift is set out of order.</p> <ul style="list-style-type: none"> <li>Check the input wiring on controller board (X05.2 -400SP and on the VF drive (T3).</li> <li>Clear the fault (see menu <a href="#">Diagnosis</a> ), and try another movement of the car. If the fault is always detected, replace 400SP board and/or the VF drive.</li> </ul>
<b>SFT2 control at startup</b> <b>SFT2 control at stop</b>	<b>OS</b>	<p>SFT2 feedback input for STO function of the VF drive, is at the wrong state at startup or after a stop.</p> <ul style="list-style-type: none"> <li>Check the input wiring on controller board (X05.5 -400SP and on the VF drive (Safety terminal).</li> <li>Clear the fault (see menu <a href="#">Diagnosis</a> ), and try another movement of the car. If the fault is always detected, replace 400SP board and/or the VF drive.</li> </ul>
<b>SFT2 control while moving</b>	<b>ALR</b> then <b>OS</b>	<p>SFT2 feedback input for STO function of the VF drive, is at the wrong state during a movement. If it occurs 5 consecutive times, lift is set out of order.</p> <ul style="list-style-type: none"> <li>Check the input wiring on controller board (X05.5 -400SP and on the VF drive (Safety terminal).</li> <li>Clear the fault (see menu <a href="#">Diagnosis</a> ), and try another movement of the car. If the fault is always detected, replace 400SP board and/or the VF drive.</li> </ul>
<b>Run VF signal always ON</b>	<b>OS</b>	<p>The VF drive output to enable the movement is always detected ON by the controller, even after a stop command</p> <ul style="list-style-type: none"> <li>Check the input wiring on controller board (X05.3 - 400SP) and on the VF drive (T3 terminal).</li> </ul>
<b>Brake VF signal always ON</b>	<b>ALR</b> then <b>OS</b>	<p>The VF drive output to operates the brakes is always detected ON by the controller, whereas the output to enable the movement is OFF. After 5 consecutive detection of this fault , the lift is set out of order.</p> <ul style="list-style-type: none"> <li>Check the input wiring on controller board (X05.4 - 400SP) and on the VF drive (T3 terminal)..</li> </ul>
<b>Plan to replace traction ropes</b>	<b>ALR</b>	<p>The monitoring function of the cables wear has detected that the configured wear alert level has been reached. Plan soon to replace the cable before the lift will be set out of order</p>
<b>Traction ropes must be replaced</b>	<b>OS</b>	<p>The monitoring function of the cables wear has detected that the maximum direction reversals counter has been reached. The lift is set out of service until the cables are replaced. The fault will be cleared only when the controller will be informed that the replacement has been realized; this action is done in the menu <a href="#">Ropes wear</a>.</p>

## Shaft reader faults

### • ABSOLUTE READER

Title	Severity	Description
<b>Shaft reader error</b>	<b>OSU</b>	The shaft reader has an internal fault; it shall be replaced.
<b>Shaft reader invalid datas</b>	<b>OSU</b>	The car position detected by the shaft reader is out of the range determined by the heights defined during the shaft's learning phase. <ul style="list-style-type: none"> <li>• Carry out a new shaft's learning phase (see <a href="#">Shaft's learning phase</a> )</li> </ul>
<b>Two floors have the same height</b>	<b>OSU</b>	Once the shaft's learning phase has been performed, two floors have the same height's value, which is a fault case for the controller. <ul style="list-style-type: none"> <li>• Change manually the heights in the menu Equipments Reader menu</li> <li>• Carry out a new shaft's learning phase (see <a href="#">Shaft's learning phase</a> )</li> </ul>
<b>Two floors have opposite heights</b>	<b>OSU</b>	Once the shaft's learning phase has been performed, one floor has an higher height value than another upper floor in the shaft. <ul style="list-style-type: none"> <li>• Change manually the heights in the menu Equipments Reader menu</li> <li>• Carry out a new shaft's learning phase (see <a href="#">Shaft's learning phase</a> )</li> </ul>
<b>Wrong shaft reader</b>	<b>OSU</b>	The shaft reader detected by the contrller doesn't match the one configured <ul style="list-style-type: none"> <li>• Check the configuration in the menu <a href="#">PCustomization -&gt; Equipments -&gt; Shaft reader</a></li> </ul>
<b>Missing shaft reader</b> <b>Shaft reader communication</b>	<b>OSU</b>	The controller can't communicate with the shaft reader <ul style="list-style-type: none"> <li>• Check the connection of the shaft reader in the inspection box (X31-415SP)</li> <li>• Check the position of dip-switches S1 ,that must be set to ON if X29 and X30 on 410SP board, are empty.</li> </ul>

### • FLAGS READER

Title	Severity	Description
<b>Reader not calibrated</b>	<b>ALR</b>	Indicates that a calibration phase has to be done before turning the lift in service for users.
<b>Reader calibration error</b>	<b>ALR then OSU</b>	The calibration of the reader has failed. After 3 failed attempts, the lift is set out of order. <ul style="list-style-type: none"> <li>• Check the placement of each flag in the shaft.</li> <li>• Check the placement of the down slowdown flag.</li> <li>• Check the wiring of each sensors (A, B, C, RB &amp; RH)</li> </ul>
<b>Reader input XX error</b>	<b>ALR</b>	Input A, B or C of the flag reader is not correctly detected while the car is moving. Then , the car stops, and a calibration phase is launched. <ul style="list-style-type: none"> <li>• Check the wiring of the matching sensor</li> </ul>
<b>Door area is missing</b>	<b>ALR</b>	On arrival at the floor, the door area flag is not detected. <ul style="list-style-type: none"> <li>• Check the placement of the door zone flag at the floor detected</li> </ul>
<b>Door area wrongly placed</b>	<b>ALR</b>	A door area flag has been detected between two floors.Then , the car stops, and a calibration phase is launched.This fault may be detected by one of the following cases : <ul style="list-style-type: none"> <li>• A stopping or slowdown flag is missing, the reader can shift its position.</li> <li>• Two stopping or slowdown flags are too close together, i.e. a closer than the distance between sensor A and sensor B.</li> <li>• A stopping flag is still active while the door flag is not.</li> </ul>
<b>Door area never detected</b>	<b>ALR</b>	During a travel across several floors, no door area flags have been detected. Then , the car stops, and a calibration phase is launched. <ul style="list-style-type: none"> <li>• Check the presence of sensor C and its wiring.</li> <li>• Check also the correct alignment in front of the flag..</li> </ul>
<b>End slowdown flags detected together</b>	<b>OSU</b>	RB & RH sensors (connected on X12 of 410SP board)for end slowdown area detection are both enabled. <ul style="list-style-type: none"> <li>• Check the presence of RH &amp; RB flags in the shaft.</li> <li>• Check also the correct alignment of the sensors in front of the flags...</li> </ul>

## Relevelling faults

Title	Severity	Description
<b>Unintended car movement</b>	<b>OSM</b>	<p>The car has overpassed the unlocking door zone while a relevelling or levelling operation was in progress.</p> <ul style="list-style-type: none"> <li>• Check the correct disposal of the magnet used for the unlocking door zone</li> <li>• Check the brake system (leveling only)</li> </ul>
<b>Safety relay always ON</b>	<b>OSU</b>	<p>The safety relay is closed with the car out of an unlocking door zone The lift will get back in order as soon as relay is in the correct state</p> <ul style="list-style-type: none"> <li>• Check the safety relay wiring</li> <li>• Check the magnet sensor and its cable</li> <li>• Check the connection of the magnet sensor on X11 terminal of 415SP board</li> </ul>
<b>Safety relay always OFF</b>	<b>ALR</b>	<p>The safety relay didn't close as requested for a relevelling/levelling operation</p> <ul style="list-style-type: none"> <li>• Check the correct disposal of the magnet used for the unlocking door zone</li> <li>• Check the safety relay wiring</li> </ul>
<b>Relevelling too long</b>	<b>OSU</b>	<p>The car did not reach back the floor in the maximum time configured</p> <ul style="list-style-type: none"> <li>• Increase this maximum relevelling time</li> <li>• Check the speed of relevelling</li> </ul>
<b>Too many relevellings</b>	<b>OSU</b>	<p>The maximum number of consecutive relevellings at the same floor (within 2 minutes) has been reached..</p> <ul style="list-style-type: none"> <li>• Check the relevelling start and stop distances</li> <li>• Increase the value of this counter</li> </ul>
<b>Unlocking door zone error</b>	<b>OS</b>	<p>The unlocking door zone has been detected 1meter far from the nearest floor.</p> <ul style="list-style-type: none"> <li>• Check the correct disposal of the magnet used for the unlocking door zone</li> <li>• Check the connection of the magnet sensor on X06 terminal of 315SP board</li> </ul>

## Other faults

Title	Severity	Description
<b>Anti-creep always active</b>	<b>OSM</b>	<p>This fault only concerns the overspeed governor with a parking coil to prevent the creep of the car. It is detected when the coil is powered to make the car move, but the monitoring input of its state indicates that the overspeed governor is not released.</p> <ul style="list-style-type: none"> <li>• Check the wiring of the monitoring input on 433SP or 428SP board</li> <li>• Check the configuration of this input and its polarity which has to be NC.</li> <li>• Check the proper operation of the coil.</li> </ul>
<b>Anti-creep always inactive</b>	<b>OSM</b>	<p>This fault only concerns the overspeed governor with a parking coil to prevent the creep of the car. It is detected when the coil is not powered to ensure the car is stopped, but the monitoring input of its state indicates that the overspeed governor is still released.</p> <ul style="list-style-type: none"> <li>• Check the wiring of the monitoring input on 433SP or 428SP board</li> <li>• Check the configuration of this input and its polarity which has to be NC.</li> <li>• Check the proper operation of the coil.</li> </ul>

## Doors faults

Title	Severity	Description
<b>Closing limit switch defective (door 1 or 2)</b>	<b>ALR</b> then <b>OSU</b>	The closing limit switch is not detected when the door is supposed to be closed. <ul style="list-style-type: none"> <li>Check the wiring (X08.2-415SP door 1,, X44.2-417SP door 2).</li> </ul>
<b>Opening limit switch defective (door 1 or 2)</b>	<b>ALR</b>	The closing limit switch is not detected when the door is supposed to be closed. <ul style="list-style-type: none"> <li>Check the wiring (X08.3-415SP door 1, X44.3-417SP door 2).</li> </ul>
<b>Door motor overheating (door 1 or 2)</b>	<b>ALR</b> then <b>OSU</b>	The door motor thermal probe indicates an overheating <ul style="list-style-type: none"> <li>Check the motor is not permanently powered</li> <li>Check the wiring (X08.5-415SP door 1, X44.5-417SP door 2).</li> </ul>

## Safety chain faults

Title	Severity	Description
<b>Memorized primary security engaged</b>	<b>OSM</b>	One of the primary safety contact bypassed by emergency operation box (safety gear, end limit switch, overspeed governor) is or was open.
<b>Emergency stop activated</b>	<b>OST</b>	One of the primary safety contact (MCY stops, wheel, toe-guard...) is open
<b>Safety chain power supply failure</b>	<b>OS</b>	Supply voltage for the safety chain is missing <ul style="list-style-type: none"> <li>Check DJD4 earth leak circuit breaker in the controller cabinet.</li> </ul>
<b>Car door safety contact defective</b>	<b>OSU</b>	Despite several attempts to close the car door , the associated safety contact is still open <ul style="list-style-type: none"> <li>Check the position of the safety contact.</li> </ul>
<b>Hall door safety contact</b>	<b>OSU</b>	Despite several attempts to close the hall door , the associated safety contact is still open <ul style="list-style-type: none"> <li>Check the position of the safety contact.</li> </ul>
<b>Hall door locking contact</b>	<b>OSU</b>	Despite several attempts to lock the hall door , the associated safety contact is still open <ul style="list-style-type: none"> <li>Check the position of the safety contact.</li> </ul>
<b>Locking safety contact open while moving</b>	<b>ALR</b>	The landing door locking safety contact opened during movement of the car Le contact de verrouillage des portes palières s'est ouvert pendant un déplacement. <ul style="list-style-type: none"> <li>Check the landing door lock contact and the hook on the car door.</li> </ul>
<b>DBD active</b>	<b>OSU</b>	The door bypass device is engaged, while the lift is not in maintenance mode (inspection, emergency operation, temporary). <ul style="list-style-type: none"> <li>Check the DBD connectors X13 to X16 on 405SP board</li> </ul>
<b>Safety chain closed with a door open</b>	<b>OSU</b>	In user mode, the safety chain kept closed with a door totally open <ul style="list-style-type: none"> <li>Check the locking door contacts is not bypassed on connector X19 of the 405SP board</li> </ul>
<b>Safety chain closed during stop in maintenance mode</b>	<b>ALR</b>	In maintenance mode (inspection, emergency operation, temporary) the safety chain is closed while the car is stopped. <ul style="list-style-type: none"> <li>Check the primary safety contact are not bypassed.</li> </ul>
<b>Safety chain closed while cam is released</b>	<b>OSU</b>	In user mode, with car available at the floor, the landing doors locking contact is closed although the cam is not engaged. <ul style="list-style-type: none"> <li>Check the locking door contacts is not bypassed on connector X19 of the 405SP board</li> </ul>
<b>Safety chain closed with loading pawls released</b>	<b>OSU</b>	In user mode, with car stopped, the safety chain is closed although the loading pawls are released. <ul style="list-style-type: none"> <li>Check that the safety contacts of the loading pawls on connector X12 of the 405SP board</li> </ul>
<b>Toe-guard safety contact isn't properly wired</b>	<b>ALR</b>	The safety chain is closed in the low area of the despite the toe guard despite the toe guard safety contact isn't bypassed. <ul style="list-style-type: none"> <li>Check the wiring of the bypass switch on X07 of 415SP board</li> <li>Check the wiring of the toe guard safety contact on X08 (and X09 if there is a second toe guard)of 415SP board</li> </ul>
<b>Toe-guard is bypassed beyond the low area of the shaft</b>	<b>OS</b>	The safety contact of the toe guard is bypassed despite the car is not in the low area of the shaft and the toe guard is unfold <ul style="list-style-type: none"> <li>Check the wiring of the bypass switch on X07 of 415SP board</li> </ul>

## ANNEX A : Commissioning tests assistance

The TETRA controller integrates assistance to easily carry out the examinations and tests required by the EN81-20 standard in chapter 6.3. before commissioning the lift..

All these tests are available from the application 

### Safety gear test

This test is required in chapter 6.3.4 of EN81-20 standard. It helps to check the correct operation of the safety gear of the lift. It requires that the overspeed governor may be electrically remotely triggered

#### ATTENTION

To prevent any material damages of the lift, it is recommended to decrease the nominal moving speed during this test.

#### IMPORTANT

In case of a **SEL20** overspeed governor model, it is mandatory to unplug **X22** of the 410SP board.

#### STEP 1

- Launch the test from menu **Commissioning tests** of the SprinteControl App, then **Safety Gear Test**. Then press the "Next" button, to launch the test.

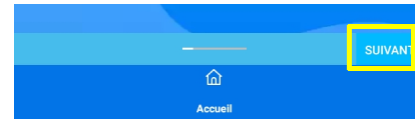

#### STEP 2

- Press "Up" or "Down" to move the car in the desired direction, then press "OK" whenever you want, to trip the overspeed governor

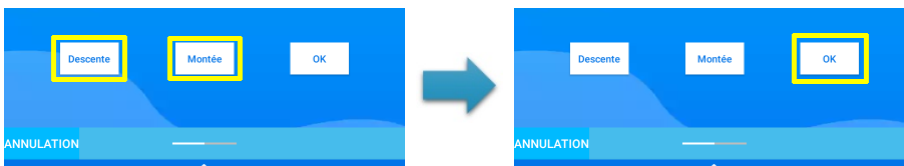

When pressing OK, the coil of the governor is powered for 2s, thus blocking itself, and therefore engaging the safety gear of the car.

#### STEP 3

- Finally press "End" button to exit the tripping of the overspeed governor.

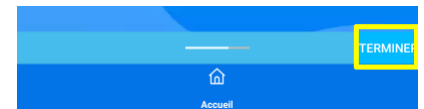

#### STEP 4

- Check on the dashboard, the opening of the safety chain at SP3 point and check also in the fault list of Diagnosis menu, that the fault "Memorized primary security engaged" is recorded.

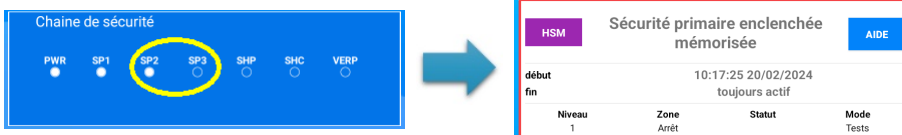

#### NOTE

To get back the lift in order, you will have to reengage the overspeed governor, and then clear the fault recorded in the list.

#### IMPORTANT

In case of a **SEL20** overspeed governor model, it is mandatory to plug back **X22** of the 410SP board.

## Brakes self-monitoring test (with ADL300 drive)

This test checks the self-monitoring of the safety brakes used as the stopping means in the protection device against unintended car movement. This test is required in chapter 6.3.13 of the EN81-20 standard.

This brakes self-monitoring, performed by the inverter, is tested by lifting the brakes one after the other and then check the inverter has detected the corresponding fault in both cases.

### IMPORTANT

*The brakes self monitoring is a control fulfilled by the frequency inverter. The procedure described here is only valid for Tetra controller equipped with the frequency inverter **ADL300** from **WEG**.*

#### STEP 1

- Switch the lift in emergency operation.

#### STEP 2

- Launch the test from menu **Tests** of the SprinteControl application, then **Brakes self-monitoring test**

#### STEP 3

- Keep pressed the Up button of emergency operation box, as soon as it's announced, in order to test brake #1..

#### STEP 4

- As soon as the up button is pressed, brake #1 is lifted without any move order, and after 5s maximum:
  - If a fault has been detected by the inverter, brake #1 test has **succeeded**.
  - If none fault has been detected by the inverter, brake #1 test has **failed**.
- Release the button to go on brake #2 test.

#### STEP 5

- Keep pressed the Down button of emergency operation box, as soon as it's announced, in order to test brake #2.

#### STEP 6

- As soon as the down button is pressed, brake #2 is lifted without any move order, and after 5s maximum:
  - If a fault has been detected by the inverter, brake #2 test has **succeeded**.
  - If none fault has been detected by the inverter, brake #2 test has **failed**.

#### STEP 7

- The brakes self-monitoring test is now over;
  - This function is **valid** if both brakes tests have succeeded.  
In that case the lift will be kept out of order , until the deletion of the faults (.with application on tablet);
  - This function is **not valid** if only one of both brakes tests has failed.  
Check the correct wiring and the settings for the brakes microswitches, then check the mechanical operation of the brakes.

### NOTE

*In cas of test failure, check the activation of the brakes self monitoring function :  
Menu **CUSTOMIZATION EQUIPEMENT HOIST FREINS Autocontrôle des freins***

## Brakes self-monitoring test(with ZAdyn drive)

This test checks the self-monitoring of the safety brakes used as the stopping means in the protection device against unintended car movement. This test is required in chapter 6.3.13 of the EN81-20 standard. This brakes self-monitoring, performed by the inverter, is tested by keeping the brakes contacts signals open on the inverter at the end of a car movement, to check thaht a fault is properly detected.

### IMPORTANT

The procedure described here is only valid for Tetra controller equipped with the frequency inverter ZAdyn (Pro or 4CS) from ZIEHL-ABEGG.

### STEP 1

- Lift in user mode, make a car call to the last floor by pressing the up button of the emergency recall box 

### STEP 2

- While the car is moving, disconnect CFR connectors located close to the inverter

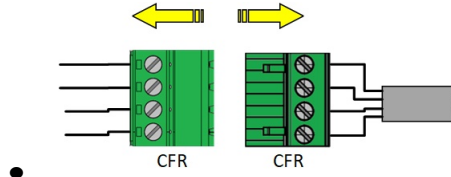

### NOTE

if CFR can't be accessed, disconnect the brakes contacts signals directly on the inverter terminals :

Terminal X-MON on ZADyn-4CS

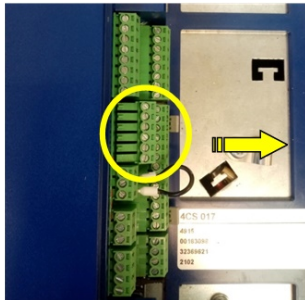

Terminal X-BR on ZADynPro

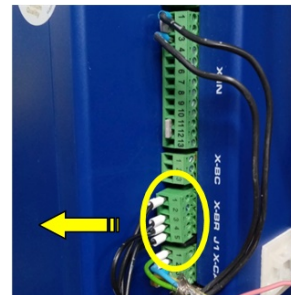

- ONce arrived, the car doesn't open the doors et and the lift is set out of order. ..

### STEP 3

- If, once arrived, the lift doesn't open the doors and go into out of order with "**Brakes control alarm**" recorded (menu **DIAGNOSIS DEFAULTS**) :

OOM		Brakes control alarm		HELP
begin	08:26:49 11/09/2024			
end	always active			
Level	Zone	Status	Mode	
7	Stop	On coming	User	

the brakes self-monitoring test has **succeeded**.

- If, once arrived , the lift is still use and no fault has been detected, brakes self-monitoring test has **failed**.

### NOTE

In cas of test failure, check the activation of the brakes self monitoring function :in the ZAdyn inverter In menu **CUSTOMIZATION EQUIPEMENT HOIST FREINS**, parameter **Brakes contact polarity** has to be different from **OFF**

## Upward overspeed protection mean test

This test is required in chapter 6.3.11 of EN81-20 standard. It helps to check the correct operation of the upward overspeed protection mean

This protection mean is either an upward/downward safety gear, either an upward /downward detection overspeed governor with a safety contact that will release the brakes.

This test requires that the overspeed governor shall be electrically remotely triggered

### ATTENTION

*To prevent any material damages of the lift, it is recommended to decrease the nominal moving speed during this test.*

#### STEP 1

- Launch the test from menu **Commissioning tests** of the SprinteControl app, then **Upward overspeed protection mean Test**

#### STEP 2

- The car shall be empty; push OK to start the test: the car goes to the lowest floor in case it's not already there

#### STEP 3

- Once the car is at the lowest floor, push OK to move the car upward at nominal speed in emergency operation

#### STEP 4

- The safety gear will be triggered as soon as the car will reach the nominal speed within a door unlocking zone.

#### STEP 5

- 2 seconds after triggering the overspeed governor
  - If the car stopped or has been slowed down, the test has **succeeded**
  - If no stop or slow down of the car has been detected, the test has **failed**

## Anti-skidding test

The detection of the non-movement of the cabin while a travel has been ordered (due to ropes skidding on the pulley in case of traction lifts) is required in chapter 5.9.2.7 of EN81-20 standard.

This test helps to check this detection, the memorization of the matching fault in case of main power supply failure and the need of intervention (clearing faults) to have the lift back in service.

### NOTE

*To perform this test, the lift shall be in user mode, with car available at level*

### STEP 1

- Launch the test from menu **Commissioning tests** of the SprinteControl app, then **Anti-skidding test**

### STEP 2

- Push the OK button on the controller to perform a user request to the next floor.

### STEP 3

- The travel is ordered with a travel speed close to zero (1mm/s)

### STEP 4

- After a time duration equal to the skidding timer plus 2 seconds, the test is over;
  - The test has **succeeded** if the lift is now out of order with the fault "No car movement detected" recorded. In that case the lift will be kept out of order, until the deletion of the faults (.with application on tablet);
  - The test has **failed** if the lift is back in service without any fault recorded.

## End limit switches test

The final limit switches shall open the safety chain as required in chapter 5.12.2.3.1 of EN81-20 standard. This test helps to check this detection, the memorization of the matching fault in case of main power supply failure and the need of intervention (clearing faults) to have the lift back in service.

### NOTE

To perform this test, the lift shall be in user mode, with car available at level

#### STEP 1

- Launch the test from menu **Commissioning tests** of the SprinteControl app, then **End Limit switches**

#### STEP 2

- Push the UP button of the emergency recall box, to test the up end limit switch or the DOWN button to test the down end limit switch

#### STEP 3

- The car is moving toward the extreme floor matching the end limit to test, if it is not already located there

#### STEP 4

- Once the car is stopped, press OK button of the controller : the car is moving toward the end limit switch at inspection speed

#### STEP 5

- After a maximum moving duration of 10s :
  - The test has **succeeded** if the lift is now out of order with the fault "Memorized primary security engaged." recorded and the safety chain is opened..  
Go to step 6
  - The test has **failed** if the safety chain is not opened.

#### STEP 6

- Switch to emergency recall operation and move back the car to the floor
- Switch back to normal mode and delete the faults (.with application on tablet)
- 5s later, the lift is back in service

## Test of the natural movement of the car

This test is required in chapter 6.3.1 c) of the EN81-20 standard ; it aims to check the natural movement of the car when the brakes are manually released.

### STEP 1

- Place the load in car , according to the following table and the balance factor of the lift :

Balance factor	Load in car ( percentage of rated load)
0,40	entre 30% et 50%
0,45	entre 35% et 55%
0,50	entre 40% et 60%
0,55	entre 45% et 65%
0,60	entre 50% et 70%

Example: For a 1000kg lift with a balance factor of 0,4 the load in car shall be between 300kg to 500kg

### STEP 2

- Launch the test from menu **Commissioning tests** of the SprinteControl App, then **Test of the natural movement of the car** and push OK to confirm

### STEP 3

- Switch to emergency operation, then push together Up & Down emergency operation buttons to release the brakes

#### NOTE

*If the safety chain is open, the doors will be closed.  
Don't release the buttons at this time*

### STEP 4

- After 5s maximum with the brakes released
  - The test has **succeeded** if the car has moved more than 1 cm
  - The test has **failed** if the car hasn't moved

## Braking force test

This test is required in chapter 6.3.1 b) of the EN81-20 standard ; on order to check only one brake of the machine is able to slow down the car with its rated load in downward direction.  
It has to be performed for each brake.

### NOTE

*To perform this test, the lift shall be in user mode, with car available at level*

#### STEP 1

- First, load the car to the rated load of the lift

#### STEP 2

- Launch the test from menu **Commissioning tests** of the SprinteControl app, then **Braking force test (brake 1 or brake 2)** and push OK to confirm

#### STEP 3

- The car is first moved to the highest floor.

#### STEP 4

- Once the car is stopped, push OK to move it downward at nominal speed

#### STEP 5

- The car is moving downward, once the nominal speed is reached, one of the brakes is released

#### STEP 6

- After 1 second only :
  - The test has **succeeded** if the car is under 90% of its nominal speed
  - The test has **failed** if the car hasn't slowed down enough

The second brake is immediately released

## Brakes efficiency test

This test is required in chapter 6.3.1 a) of the EN81-20 standard ; in order to check only the brakes of the machine are able to stop the car in downward direction, with an overload of 25%

### NOTE

To perform this test, the lift shall be in user mode, with car available at level

#### STEP 1

- First, load the car to 125% of the rated load of the lift

#### STEP 2

- Launch the test from menu **Commissioning tests** of the SprinteControl app, then **Brakes efficiency test (brake 1 or brake 2)** and push OK to confirm

#### STEP 3

- The car is first moved to a higher level floor.

#### STEP 4

- Once the car is stopped, push OK to move it downward at nominal speed

#### STEP 5

- The car is moving downward, once the nominal speed is reached, the brakes are released

#### STEP 6

- After 2 seconds only :
  - The test has **succeeded** if the car has stopped
  - The test has **failed** if the car didn't stop on time

## Re-leveling test

This test is required in chapter 6.3.12 of the EN81-20 standard , in order to verify the car maintains the leveling accuracy. It also helps to check the detection and the stopping of an unintended car movement as required in chapter 6.3.13 of the EN81-20 standard



### NOTE

To perform this test, the lift shall be in user mode, with car available at level

### STEP 1

- The doors are opening first. All the test is performed with the doors open, in order to chek the safety relay effectively bypasses the doors safety contacts.

### STEP 2

- Keep the emergency operation up button  pressed to move the car upward ,  
or down button  to move it downwardsAu.

### STEP 3

- Once the button is released, the car stops and gets back to the floor.
- The test restarts at **STEP 2**.



## Test of the unintended car movement protection mean

This test is required in chapter 6.3.13 of the EN81-20 standard , in order to verify the proper operation of the detection , activation and stopping components of this UCM protection mean.

### STEP 1

- Run the re-levelling test described above to check the protection against an unintended car movement.

### STEP 2

- Once the doors are open press the emergency operation up button  to move the car upward ,  
or press down button  to move it downwards.

### STEP 3

- Keep the button pressed until the car leaves the unlocking door zone.

### STEP 4

- The safety chain shall open at the car door closing contact SHC (or SHP if a swing door is open at the landing), thus activating the stopping mean of the car to stop its movement.

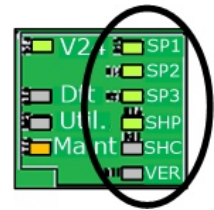

### STEP 5

- The re-levelling test is cancelled and the lift is set out of order with "Unintended car movement" fault recorded.

## Measurement of the insulation resistance

The measurement of the insulation resistance of the different electrical circuits is required in chapter 6.3.2.c) of EN81-20 standard

### SAFETY PRELIMINARY OPERATIONS

#### IMPORTANT



Usage of your PPE is mandatory for all of the measurements described below

#### DANGER



- Switch off the main power supply circuit breaker **DJ1**
- Switch off the earth leak circuit break for car lighting **DJD1**
- Switch off the earth leak circuit break for shaft lighting **DJD2**
- All downstream circuit breakers has to be switched ON
- Check for the absence of voltage out of the above mentioned circuit breakers before proceeding the measurements

#### NOTE

For all of the tests below, the measurement is done from the circuit to test to the earth   
The tests have to be carried out with a maximum voltage of 500Vdc  
The electrical insulation is correct if the measured resistance is  $> 1M\Omega$

#### TEST 1

#### Check of main power and lighting circuits

Short circuit terminals L1, L2 et L3 on the output of main power circuit breaker DJ1.

- Carry out the measurement on the outputs now short-circuited

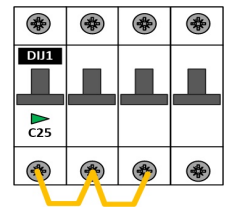

Short circuit terminals N & P on the output of car lighting earth leakwer circuit breaker DJD1.

- Carry out the measurement on the outputs now short-circuited

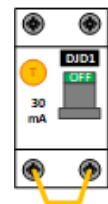

Short circuit terminals N & P on the output of car lighting earth leakwer circuit breaker DJD2.

- Carry out the measurement on the outputs now short-circuited

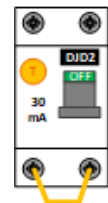

#### TEST 2

#### Check of the safety chain

Short-circuit terminals N & P on the output of safety chain earth-leakage circuit breaker DJD4.

- Carry out the measurement on the outputs now short-circuited

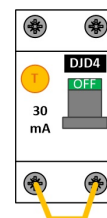

- Carry out the measurement on the entrance point of the safety chain,  
terminal **X02-1** board **405SP**
- Carry out the measurement on the whole primary safety contacts ,  
terminal **X22-5** board **405SP**
- Carry out the measurement on the whole car doors safety contacts ,  
terminal **X22-3** board **405SP**
- Carry out the measurement on the whole landing doors closing contacts ,  
terminal **X22-4** board **405SP**
- Carry out the measurement on the whole landing doors locking contacts ,  
terminal **X22-6** board **405SP**
- Carry out the measurement on the end point of the safety chain ,  
terminal **X12-1** board **405SP**

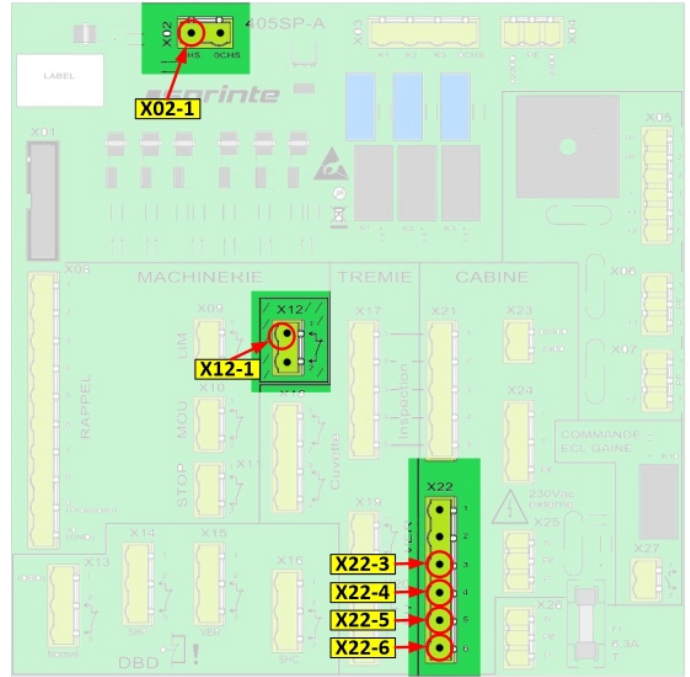

## TEST 3

### Check of the motor circuits and braking resistor

Unplug the power connector of the VF drive.

- Carry out the measurement on terminal BR and C1 of this connector
- Carry out the measurement on terminals U, V & W motor phases of this connector

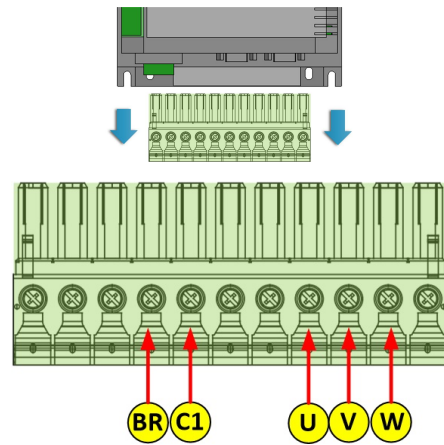

## TEST 4

### Check of the brakes circuits

Unplug the brakes coils connector **X06** & **X07** from **405SP** board

- Carry out the measurement on terminal 1 ( **-** ) and terminal 3 ( **+** ) of both connectors

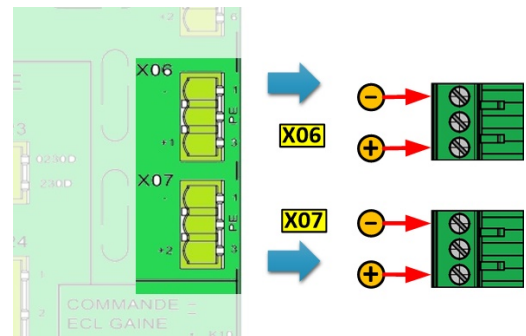

## Tripping overspeed governor

The overspeed governor may be tripped while the car is moving up, down or at stop while the lift is in normal operation mode.

### ATTENTION

To prevent any material damages of the lift, it is recommended to decrease the nominal moving speed during this test.

### IMPORTANT

In case of a **SEL20** overspeed governor model, it is mandatory to unplug **X22** of the 410SP board.

### STEP 1

- Go to the Tools menu of SprinteControl App then **Lift Tools** **Overspeed governor commands** **Trig the car's OSG.**

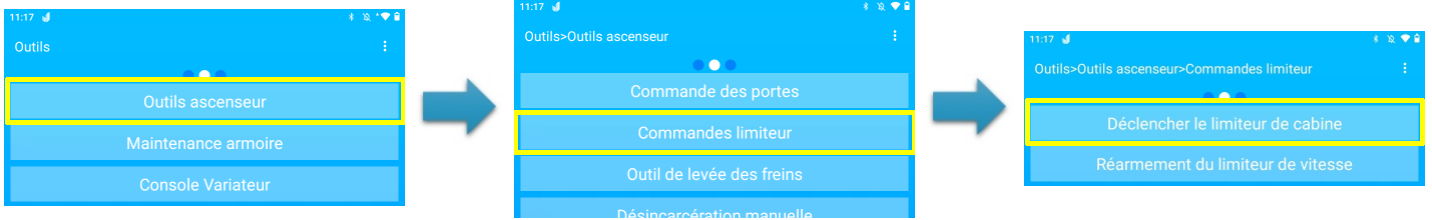

### STEP 2

- Press the "Next" button, to launch the tripping of the overspeed governor.

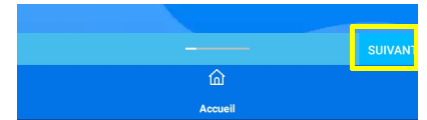

### STEP 3

- Press "Up" or "Down" to move the car in the desired direction, then press "OK" whenever you want, to trip the overspeed governor

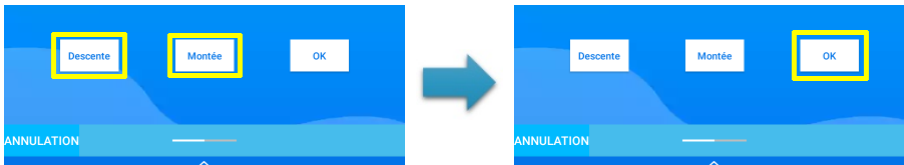

When pressing OK, the coil of the governor is powered for 2s, thus blocking itself, and therefore engaging the safety gear of the car.

### STEP 4

- Finally press "End" button to exit the tripping of the overspeed governor.



### STEP 5

- Check on the dashboard, the opening of the safety chain at SP3 point and check also in the fault list of Diagnosis menu, that the fault "Memorized primary security engaged" is recorded.

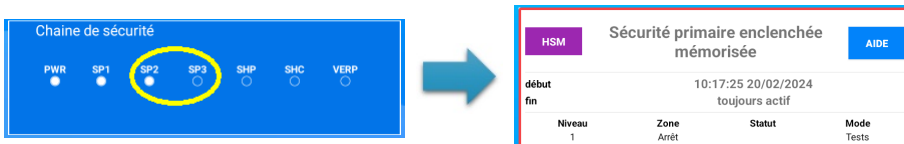

### NOTE

To get back the lift in order, you will have to reengage the overspeed governor, and then clear the fault recorded in the list.

### IMPORTANT

In case of a **SEL20** overspeed governor model, it is mandatory to plug back **X22** of the 410SP board.

## Overspeed governor reset

The following procedure helps resetting the overspeed governor if it has been tripped.

### NOTE

*This procedure is valid only for overspeed governor with electric resetting system.*

### STEP 1

- Go to the Tools menu of SprinteControl App then **Lift Tools** **Overspeed governor commands** **Resetting the car's OSG.**

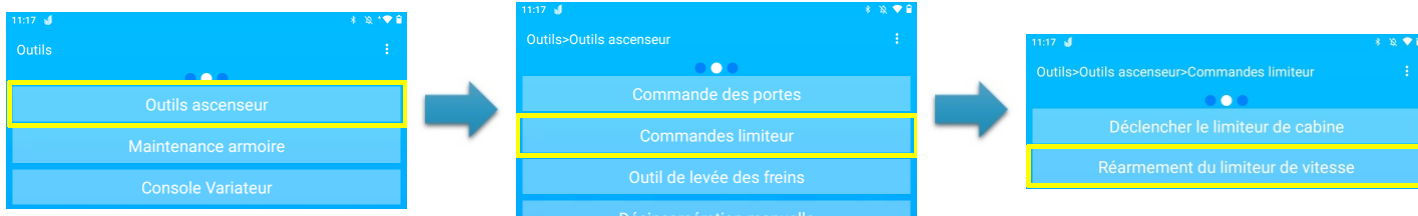

### STEP 2

- Press the "Next" button, to start the resetting of the overspeed governor.

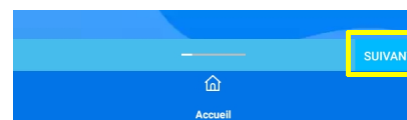

### STEP 3

- Simply press the "OK" button to reset the overspeed governor.

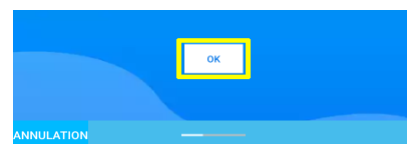

### STEP 4

- Finally press "End" button to exit the procedure.

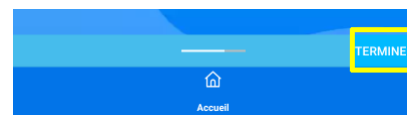

### STEP 5

- Check on the dashboard, the closing of the safety chain at SP3 point.

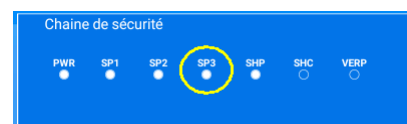

### STEP 6

- To get back the lift in order, go to the faults list of the Diagnosis menu, then clear the fault "Memorized primary security engaged" recorded.







Head office :

8 route du Barrage  
07250 Le Pouzin  
FRANCE

Tel. : +33 4 75 63 77 77

[contact@sprinte.eu](mailto:contact@sprinte.eu)

[www.sprinte.eu](http://www.sprinte.eu)

The logo for Sprinte features a blue square icon to the left of the word "sprinte" in a bold, italicized, white sans-serif font. Below "sprinte" is the tagline "move your lift" in a smaller, lowercase, italicized white sans-serif font.

**sprinte**  
*move your lift*